

Content

RO-flex 55	Page 5
RO-flex 85	Page 25
RO-flex 195	Page 53
Accessories	Page 71
Note: The system is also available in the same dimensions in stainless steel	
Technical description	Page 109
Regulations, Instructions	Page 122

Content RO-flex 55 ALU

Chassis	Page 7
Chain	Page 10
Drive units	Page 13
Idler units	Page 18
Wheel bends	Page 19
Horizontal bends	Page 20
Vertical bends	Page 22
Supports	Page 72
Side guides	Page 86
Accessories, general	Page 105

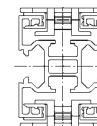

	Description	Unit	Art. No.
	<p>RO-flex 55</p> <p>Chassis profile 6m 55x63.4-F25E</p> <p>Aluminium anodized</p> <p>Length = 6.000 mm</p>	1 pcs.	301501
	<p>RO-flex 55</p> <p>Chassis profile cutting out 55x63.4-F25E</p> <p>Aluminium anodized</p> <p>By order indicate wished length (max. 6.000 mm). e.g.: length= 4.560 mm= Art. No. 301550-L4560</p>	1 pcs.	301550-L
	<p>RO-flex 55/85/195</p> <p>Slide rail white 6m 10x14W</p> <p>Superfrice</p> <p>Length = 6.000 mm</p>	1 pcs.	101001

Chassis

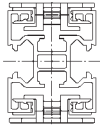

	Description	Unit	Art. No.
	<p>RO-flex 55/85/195</p> <p>Slide rail grey 6m 10x14G</p> <p>HDPE grey</p> <p>Length = 6.000 mm</p>	1 pcs.	101015
	<p>RO-flex 55/85/195</p> <p>Cylinder screw M4x8-PA</p> <p>PA 6 white</p> <p>for the fixing of the guide rail on the chassis profil</p>	100 pcs.	101050
	<p>RO-flex 55/85/195</p> <p>Connecting strip outside</p> <p>Steel galvanized incl. 4 thread pins</p>	1 pcs.	101003

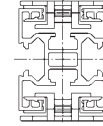

	Description	Unit	Art. No.
	<p>RO-flex 55</p> <p>Connecting strip inside</p> <p>Steel galvanized incl. 4 thread pins</p>	1 pcs.	301002
	<p>RO-flex 55/85/195</p> <p>Cover strip for chassis profile C20x3-PP</p> <p>Polypropylen Length = 3.000 mm</p>	1 pcs.	105016
	<p>RO-flex 55</p> <p>Tool MW55</p> <p>PE/Steel galvanized for mounting of guide rail</p>	1 pcs.	301030

Chain

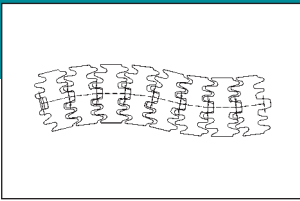

	Description	Unit	Art. No.
	<p>RO-flex 55</p> <p>Chain RT55</p> <p>POM white Length approx. 3 m</p>	1 pcs.	301700
	<p>RO-flex 55</p> <p>Chain link RT55</p> <p>POM white Single link, incl. bolt</p>	1 pcs.	301701
	<p>RO-flex 55</p> <p>Chain bolt 55-4.5x18</p> <p>Stainless steel 1.4301</p>	100 pcs.	301720

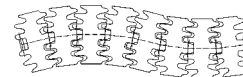

	Description	Unit	Art. No.
	<p>RO-flex 55</p> <p>Chain with strip RT55-H5.5-MA</p> <p>POM white Length approx. 3 m By order indicate strip distance.</p> <p>Example: every 6th link with strip = Art. No. 301750-MA6</p>	1 pcs.	301750-MA
	<p>RO-flex 55</p> <p>Chain link with strip RT55-H5.5</p> <p>POM white Single link, incl. bolt</p>	1 pcs.	301751
	<p>RO-flex 55</p> <p>Chain with strip RT55-H10-MA</p> <p>POM white Length approx. 3 m By order indicate strip distance.</p> <p>Example: every 6th link with strip = Art. No. 301760-MA6</p>	1 pcs.	301760-MA

Chain

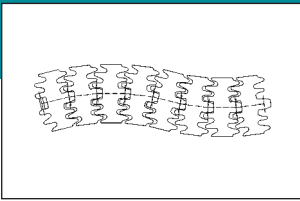

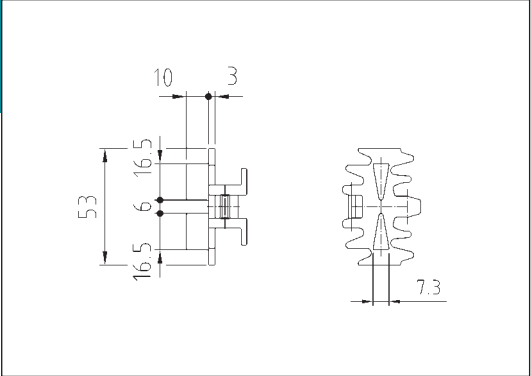
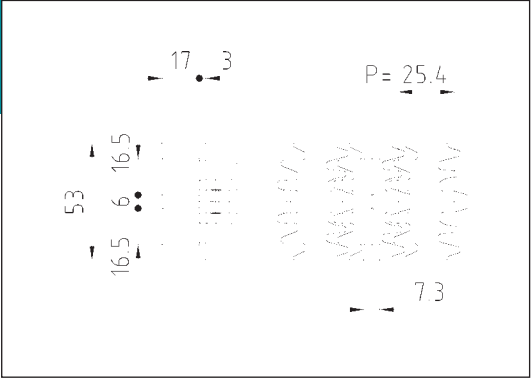
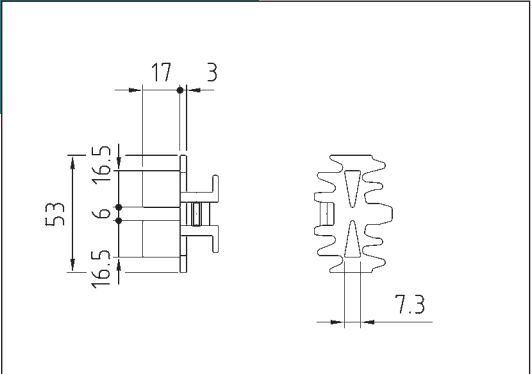
	Description	Unit	Art. No.
	<p>RO-flex 55</p> <p>Chain link with strip RT55-H10</p> <p>POM white Single link, incl. bolt</p>	1 pcs.	301761
	<p>RO-flex 55</p> <p>Chain with strip RT55-H17-MA</p> <p>POM white Length approx. 3 m By order indicate strip distance.</p> <p>Example: every 6th link with strip = Art. No. 301770-MA6</p>	1 pcs.	301770-MA
	<p>RO-flex 55</p> <p>Chain link with strip RT55-H17</p> <p>POM white Single link, incl. bolt</p>	1 pcs.	301771

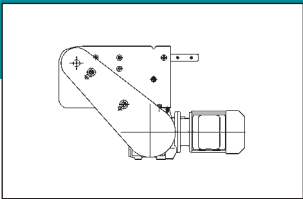

	Description	Unit	Art. No.
	<p>RO-flex 55</p> <p>Head drive station KA55-R with motor</p> <p>Motor on the right</p> <p>In the extent of supply contain: motor, sprockets, rolling chain, chain guard, attachment elements, pre-finished.</p> <p>Necessary chain length: 750 mm</p>	1 pcs.	302001
	<p>RO-flex 55</p> <p>Head drive station KA55-R without motor</p> <p>Motor on the right</p> <p>In the extent of supply contain: motor plate for gear motor SEW-S37 ..., chain guard, attachment elements.</p> <p>Necessary chain length: 750 mm</p>	1 pcs.	302001-oM
	<p>RO-flex 55</p> <p>Head drive station KA55-L with motor</p> <p>Motor on the left</p> <p>In the extent of supply contain: motor, sprockets, rolling chain, chain guard, attachment elements, pre-finished.</p> <p>Necessary chain length: 750 mm</p>	1 pcs.	302002

Drive units

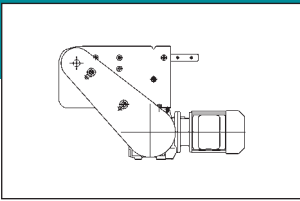

	Description	Unit	Art. No.
	<p>RO-flex 55</p> <p>Head drive station KA55-L without motor</p> <p>Motor on the left</p> <p>In the extent of supply contain: motor plate for gear motor SEW-S37 ..., chain guard, attachment elements.</p> <p>Necessary chain length: 750 mm</p>	1 pcs.	302002-oM
	<p>RO-flex 55</p> <p>Middle drive station MA55-R with motor</p> <p>Motor on the right</p> <p>In the extent of supply contain: motor, sprockets, rolling chain, chain guard, attachment elements, pre-finished.</p> <p>Necessary chain length: 820 mm</p>	1 pcs.	302020
	<p>RO-flex 55</p> <p>Middle drive station MA55-R without motor</p> <p>Motor on the right</p> <p>In the extent of supply contain: motor plate for gear motor SEW-S37 ..., chain guard, attachment elements.</p> <p>Necessary chain length: 820 mm</p>	1 pcs.	302020-oM

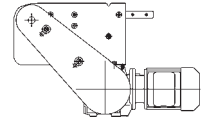

	Description	Unit	Art. No.
	<p>RO-flex 55</p> <p>Middle drive station MA55-L with motor</p> <p>Motor on the left</p> <p>In the extent of supply contain: motor, sprockets, rolling chain, chain guard, attachment elements, pre-finished.</p> <p>Necessary chain length: 820 mm</p>	1 pcs.	302021
	<p>RO-flex 55</p> <p>Middle drive station MA55-L without motor</p> <p>Motor on the left</p> <p>In the extent of supply contain: motor plate for gear motor SEW-S37 ..., chain guard, attachment elements.</p> <p>Necessary chain length: 820 mm</p>	1 pcs.	302021-oM
	<p>RO-flex 55</p> <p>Drive station RA55-R with motor</p> <p>Motor on the right</p> <p>In the extent of supply contain: motor, sprockets, rolling chain, chain guard, attachment elements, pre-finished.</p> <p>Necessary chain length: 400 mm</p>	1 pcs.	302050

Drive units

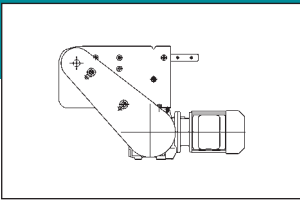

	Description	Unit	Art. No.
	<p>RO-flex 55</p> <p>Drive station RA55-R without motor</p> <p>Motor on the right</p> <p>In the extent of supply contain: motor plate for gear motor SEW-S37 ..., chain guard, attachment elements.</p> <p>Necessary chain length: 400 mm</p>	1 pcs.	302050-oM
	<p>RO-flex 55</p> <p>Drive station RA55-L with motor</p> <p>Motor on the left</p> <p>In the extent of supply contain: motor, sprockets, rolling chain, chain guard, attachment elements, pre-finished.</p> <p>Necessary chain length: 400 mm</p>	1 pcs.	302051
	<p>RO-flex 55</p> <p>Drive station RA55-L without motor</p> <p>Motor on the left</p> <p>In the extent of supply contain: motor plate for gear motor SEW-S37 ..., chain guard, attachment elements.</p> <p>Necessary chain length: 400 mm</p>	1 pcs.	302051-oM

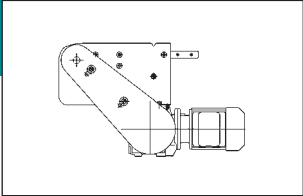

	Description	Unit	Art. No.
	<p>RO-flex 55</p> <p>Roller chain 1/2" black RK-08B-1-64E</p> <p>Endless 812.8 mm incl. coupler link</p>	1 pcs.	900901
	<p>RO-flex 55/85/195</p> <p>Chain sprocket 1/2 " -Z15</p> <p>Chain sprocket 1/2 " -Z16</p> <p>Chain sprocket 1/2 " -Z17</p> <p>Chain sprocket 1/2 " -Z18</p> <p>Chain sprocket 1/2 " -Z19</p> <p>Chain sprocket 1/2 " -Z20</p> <p>Chain sprocket 1/2 " -Z21</p> <p>Chain sprocket 1/2 " -Z22</p> <p>Steel galvanized Drilling 20H7 with wedge lane, incl. thread pencil</p> <p>fitting to drive shaft (to max. Z18) and gear motor SEW-S37 ...</p>	<p>1 pcs.</p> <p>1 pcs.</p> <p>1 pcs.</p> <p>1 pcs.</p> <p>1 pcs.</p> <p>1 pcs.</p> <p>1 pcs.</p> <p>1 pcs.</p>	<p>102131</p> <p>102132</p> <p>102133</p> <p>102134</p> <p>102135</p> <p>102136</p> <p>102137</p> <p>102138</p>

Idler units

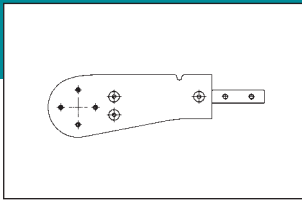

	Description	Unit	Art. No.
	<p>RO-flex 55</p> <p>Idler 180°</p> <p>PE/Steel galvanized incl. fastening elements</p> <p>Necessary chain length: 550 mm</p>	1 pcs.	302501

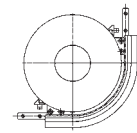

	Description	Unit	Art. No.
	<p>RO-flex 55</p> <p>Wheel bend 90°</p> <p>Aluminium/PC and Steel galvanized incl. fastening elements</p> <p>Necessary chain length: 650 mm Necessary guide rail: 695 mm</p>	<p>1 pcs.</p>	<p>304004</p>
	<p>RO-flex 55</p> <p>Wheel bend 180°</p> <p>Aluminium/PC and Steel galvanized incl. fastening elements</p> <p>Necessary chain length: 1.050 mm Necessary guide rail: 1.130 mm</p>	<p>1 pcs.</p>	<p>304005</p>

Horizontal bends

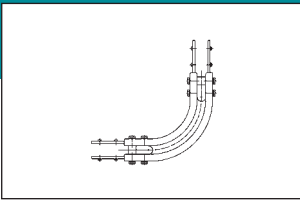

	Description	Unit	Art. No.
	<p>RO-flex 55</p> <p>Horizontal bend 15°</p> <p>PE/steel galvanized, incl. fastening elements Radius R= 125 mm</p> <p>Necessary chain length: 325 mm</p>	1 pcs.	303051
	<p>RO-flex 55</p> <p>Horizontal bend 30°</p> <p>PE/steel galvanized, incl. fastening elements Radius R= 125 mm</p> <p>Necessary chain length: 390 mm</p>	1 pcs.	303052
	<p>RO-flex 55</p> <p>Horizontal bend 45°</p> <p>PE/steel galvanized, incl. fastening elements Radius R= 125 mm</p> <p>Necessary chain length: 460 mm</p>	1 pcs.	303053

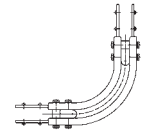

	Description	Unit	Art. No.
	<p>RO-flex 55</p> <p>Horizontal bend 60°</p> <p>PE/steel galvanized, incl. fastening elements Radius R= 125 mm</p> <p>Necessary chain length: 525 mm</p>	<p>1 pcs.</p>	<p>303054</p>
	<p>RO-flex 55</p> <p>Horizontal bend 90°</p> <p>PE/steel galvanized, incl. fastening elements Radius R= 125 mm</p> <p>Necessary chain length: 650 mm</p>	<p>1 pcs.</p>	<p>303055</p>
	<p>RO-flex 55</p> <p>Connecting strip E 20/6x120</p> <p>Steel galvanized For the direct join of bends.</p> <p>Replace the premounted strips by the strips 301608. Reuse disassembled screws.</p>	<p>1 pcs.</p>	<p>301608</p>

Vertical bends

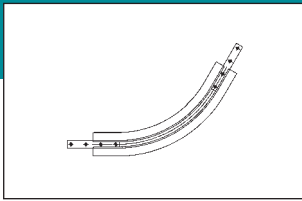

	Description	Unit	Art. No.
	<p>RO-flex 55</p> <p>Vertical bend 5°</p> <p>Aluminium, incl. fastening elements Radius R= 300 mm</p> <p>Necessary chain length: 315 mm Necessary guide rail: 625 mm</p>	1 pcs.	303501
	<p>RO-flex 55</p> <p>Vertical bend 10°</p> <p>Aluminium, incl. fastening elements Radius R= 300 mm</p> <p>Necessary chain length: 365 mm Necessary guide rail: 730 mm</p>	1 pcs.	303502
	<p>RO-flex 55</p> <p>Vertical bend 15°</p> <p>Aluminium, incl. fastening elements Radius R= 300 mm</p> <p>Necessary chain length: 420 mm Necessary guide rail: 835 mm</p>	1 pcs.	303503

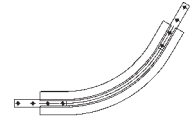

	Description	Unit	Art. No.
	<p>RO-flex 55</p> <p>Vertical bend 30°</p> <p>Aluminium, incl. fastening elements Radius R= 300 mm</p> <p>Necessary chain length: 575 mm Necessary guide rail: 1.150 mm</p>	<p>1 pcs.</p>	<p>303504</p>
	<p>RO-flex 55</p> <p>Vertical bend 45°</p> <p>Aluminium, incl. fastening elements Radius R= 300 mm</p> <p>Necessary chain length: 730 mm Necessary guide rail: 1.465 mm</p>	<p>1 pcs.</p>	<p>303505</p>
	<p>RO-flex 55</p> <p>Vertical bend 60°</p> <p>Aluminium, incl. fastening elements Radius R= 300 mm</p> <p>Necessary chain length: 890 mm Necessary guide rail: 1.775 mm</p>	<p>1 pcs.</p>	<p>303506</p>

Vertical bends

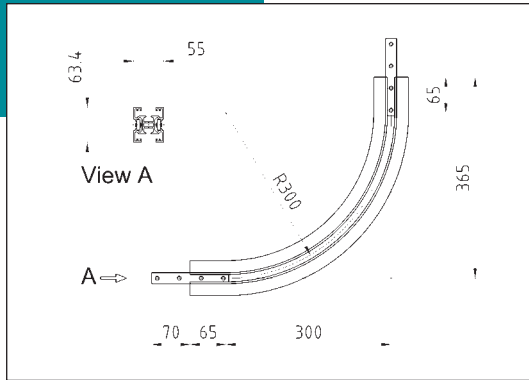
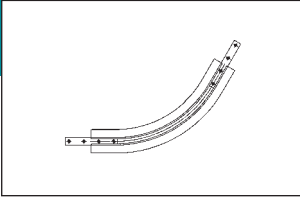

Description

Unit

Art. No.

RO-flex 55

Vertical bend 90°

1 pcs.

303507

Aluminium, incl. fastening elements
Radius R= 300 mm

Necessary chain length: 1.200 mm
Necessary guide rail: 2.400 mm

Content RO-flex 85 ALU

Chassis	Page 27
Chain	Page 31
Drive units	Page 36
Idler units	Page 41
Wheel bends	Page 43
Horizontal bends	Page 45
Vertical bends	Page 50
Supports	Page 72
Side guides	Page 86
Accessories, general	Page 105

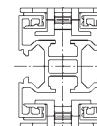

	Description	Unit	Art. No.
	<p>RO-flex 85</p> <p>Chassis profile 6m 85x75-F25E</p> <p>Aluminium anodized</p> <p>Length = 6.000 mm</p>	1 pcs.	101501
	<p>RO-flex 85</p> <p>Chassis profile cutting out 85x75-F25E</p> <p>Aluminium anodized</p> <p>By order indicate wished length (max. 6.000 mm). e.g.: length= 4.560 mm= Art. No. 101550-L4560</p>	1 pcs.	101550-L
	<p>RO-flex 55/85/195</p> <p>Slide rail white 6m 10x14W</p> <p>Superfrice</p> <p>Length = 6.000 mm</p>	1 pcs.	101001

Chassis

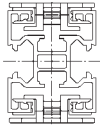

	Description	Unit	Art. No.
	<p>RO-flex 55/85/195</p> <p>Slide rail grey 6m 10x14G</p> <p>HDPE grey</p> <p>Length = 6.000 mm</p>	1 pcs.	101015
	<p>RO-flex 55/85/195</p> <p>Cylinder screw M4x8-PA</p> <p>PA 6 white</p> <p>for the fixing of the guide rail on the chassis profil</p>	100 pcs.	101050
	<p>RO-flex 85/195</p> <p>Connecting strip inside</p> <p>Steel galvanized incl. 4 thread pins</p>	1 pcs.	101002

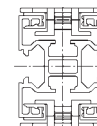

	Description	Unit	Art. No.
	<p>RO-flex 55/85/195</p> <p>Connecting strip outside</p> <p>Steel galvanized incl. 4 thread pins</p>	1 pcs.	101003
	<p>RO-flex 55/85/195</p> <p>Cover strip for chassis profile C20x3-PP</p> <p>Polypropylen Length = 3.000 mm</p>	1 pcs.	105016
	<p>RO-flex 85</p> <p>Junctions part 10°</p> <p>Aluminium/Steel galvanized incl. fastening elements</p> <p>Necessary chain length: 840 mm Necessary guide rail: 1.680 mm</p>	1 pcs.	101520

Chassis

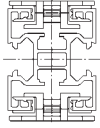

	Description	Unit	Art. No.
	<p>RO-flex 85</p> <p>Junctions part 90°</p> <p>Aluminium/Steel galvanized incl. fastening elements</p> <p>Necessary chain length: 780 mm Necessary guide rail: 1.100 mm</p>	1 pcs.	101530
	<p>RO-flex 85</p> <p>Adapter for chain assembling</p> <p>Aluminium/PE and Steel galvanized incl. fastening elements</p> <p>Necessary chain length: 160 mm</p>	1 pcs.	101540
	<p>RO-flex 85/195</p> <p>Tool MW85/195</p> <p>PE/Steel galvanized</p> <p>for mounting of guide rail</p>	1 pcs.	101030

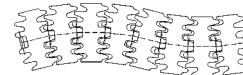

	Description	Unit	Art. No.
	<p>RO-flex 85</p> <p>Chain PLS85</p> <p>POM white Length approx. 3 m</p>	1 pcs.	101710
	<p>RO-flex 85</p> <p>Chain link PLS85</p> <p>POM white Single link, incl. bolt</p>	1 pcs.	101711
	<p>RO-flex 85</p> <p>Chain bolt 85-6.7x38.5</p> <p>Stainless steel 1.4301</p>	100 pcs.	101720

Chain

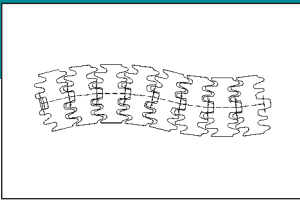

	Description	Unit	Art. No.
	<p>RO-flex 85</p> <p>Chain with strip PLS85-H5.5-MA</p> <p>POM white Length approx. 3 m By order indicate strip distance.</p> <p>Example: every 6th link with strip = Art. No. 101760-MA6</p>	1 pcs.	101760-MA
	<p>RO-flex 85</p> <p>Chain link with strip PLS85-H5.5</p> <p>POM white Single link, incl. bolt</p>	1 pcs.	101761
	<p>RO-flex 85</p> <p>Chain with strip PLS85-H10-MA</p> <p>POM white Length approx. 3 m By order indicate strip distance.</p> <p>Example: every 6th link with strip = Art. No. 101770-MA6</p>	1 pcs.	101770-MA

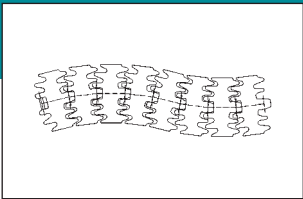

	Description	Unit	Art. No.
	<p>RO-flex 85</p> <p>Chain link with strip PLS85-H10</p> <p>POM white Single link, incl. bolt</p>	1 pcs.	101771
	<p>RO-flex 85</p> <p>Chain with strip PLS85-H17-MA</p> <p>POM white Length approx. 3 m By order indicate strip distance.</p> <p>Example: every 6th link with strip = Art. No. 101780-MA6</p>	1 pcs.	101780-MA
	<p>RO-flex 85</p> <p>Chain link with strip PLS85-H17</p> <p>POM white Single link, incl. bolt</p>	1 pcs.	101781

Chain

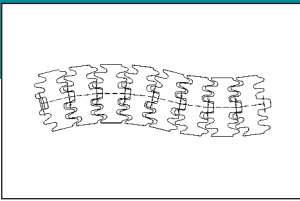

	Description	Unit	Art. No.
	<p>RO-flex 85</p> <p>Chain with strip PLS85-H40-MA</p> <p>POM white Length approx. 3 m By order indicate strip distance.</p> <p>Example: every 6th link with strip = Art. No. 101813-MA6</p>	1 pcs.	101813-MA
	<p>RO-flex 85</p> <p>Chain link with strip PLS85-H40</p> <p>POM white Single link, incl. bolt</p>	1 pcs.	101814
	<p>RO-flex 85</p> <p>Chain with adhesiv coating PLS85-white-MA</p> <p>POM white Length approx. 3 m By order indicate strip distance.</p> <p>Example: every 6th link with strip = Art. No. 101825-MA6</p>	1 pcs.	101825-MA

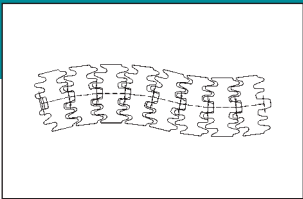

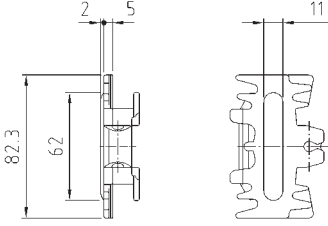
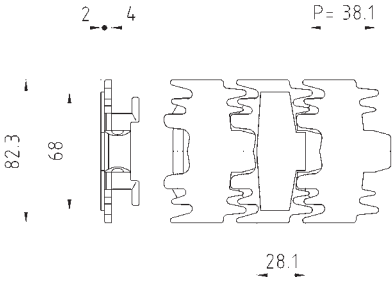
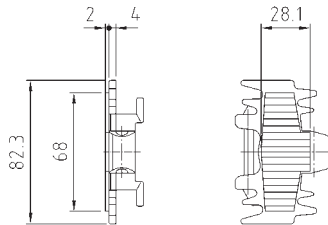
	Description	Unit	Art. No.
	<p>RO-flex 85</p> <p>Chain link with adhesiv coating PLS85-white</p> <p>POM white Single link, incl. bolt</p>	1 pcs.	101826
	<p>RO-flex 85</p> <p>Chain with adhesiv coating RT85-green-MA</p> <p>POM white Length approx. 3 m By order indicate strip distance.</p> <p>Example: every 6th link with strip = Art. No. 101835-MA6</p>	1 pcs.	101835-MA
	<p>RO-flex 85</p> <p>Chain link with adhesiv coating RT85-green</p> <p>POM white Single link, incl. bolt</p>	1 pcs.	101836

Drive units

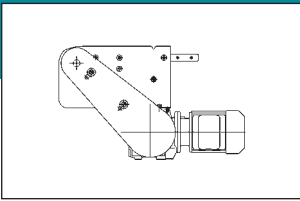

	Description	Unit	Art. No.
	<p>RO-flex 85</p> <p>Head drive station KA85-R with motor</p> <p>Motor on the right</p> <p>In the extent of supply contain: motor, sprockets, rolling chain, chain guard, attachment elements, pre-finished.</p> <p>Necessary chain length: 950 mm</p>	1 pcs.	102001
	<p>RO-flex 85</p> <p>Head drive station KA85-R without motor</p> <p>Motor on the right</p> <p>In the extent of supply contain: motor plate for gear motor SEW-S37 ..., chain guard, attachment elements.</p> <p>Necessary chain length: 950 mm</p>	1 pcs.	102001-oM
	<p>RO-flex 85</p> <p>Head drive station KA85-L with motor</p> <p>Motor on the left</p> <p>In the extent of supply contain: motor, sprockets, rolling chain, chain guard, attachment elements, pre-finished.</p> <p>Necessary chain length: 950 mm</p>	1 pcs.	102002

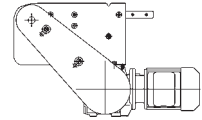

	Description	Unit	Art. No.
	<p>RO-flex 85</p> <p>Head drive station KA85-L without motor</p> <p>Motor on the left</p> <p>In the extent of supply contain: motor plate for gear motor SEW-S37 ..., chain guard, attachment elements.</p> <p>Necessary chain length: 950 mm</p>	1 pcs.	102002-oM
	<p>RO-flex 85</p> <p>Middle drive station MA85-R with motor</p> <p>Motor on the right</p> <p>In the extent of supply contain: motor, sprockets, rolling chain, chain guard, attachment elements, pre-finished.</p> <p>Necessary chain length: 940 mm</p>	1 pcs.	102450
	<p>RO-flex 85</p> <p>Middle drive station MA85-R without motor</p> <p>Motor on the right</p> <p>In the extent of supply contain: motor plate for gear motor SEW-S37 ..., chain guard, attachment elements.</p> <p>Necessary chain length: 940 mm</p>	1 pcs.	102450-oM

Drive units

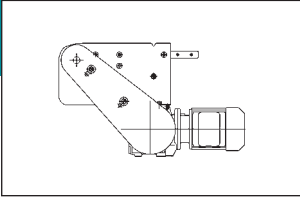

	Description	Unit	Art. No.
	<p>RO-flex 85</p> <p>Middle drive station MA85-L with motor</p> <p>Motor on the left</p> <p>In the extent of supply contain: motor, sprockets, rolling chain, chain guard, attachment elements, pre-finished.</p> <p>Necessary chain length: 940 mm</p>	1 pcs.	102451
	<p>RO-flex 85</p> <p>Middle drive station MA85-L without motor</p> <p>Motor on the left</p> <p>In the extent of supply contain: motor plate for gear motor SEW-S37 ..., chain guard, attachment elements.</p> <p>Necessary chain length: 940 mm</p>	1 pcs.	102451-oM
	<p>RO-flex 85/195</p> <p>Roller chain 1/2" black RK-08B-1-78E</p> <p>Endless 965.2 mm incl. coupler link</p>	1 pcs.	900900

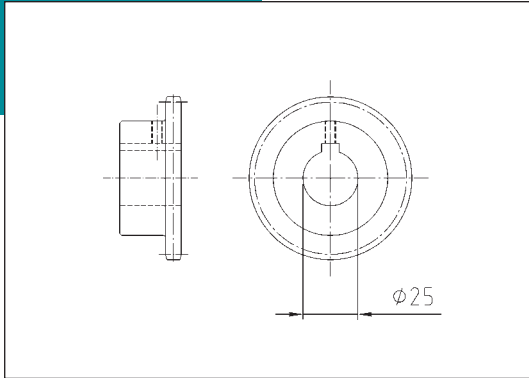
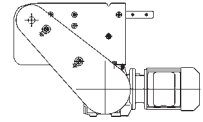

Description

Unit

Art. No.

RO-flex 85/195

Chain sprocket 1/2 " -Z15	1 pcs.	102111
Chain sprocket 1/2 " -Z16	1 pcs.	102112
Chain sprocket 1/2 " -Z17	1 pcs.	102113
Chain sprocket 1/2 " -Z18	1 pcs.	102114
Chain sprocket 1/2 " -Z19	1 pcs.	102115
Chain sprocket 1/2 " -Z20	1 pcs.	102116
Chain sprocket 1/2 " -Z21	1 pcs.	102117
Chain sprocket 1/2 " -Z22	1 pcs.	102118

Steel galvanized
Drilling 25H7 with wedge lane, incl. thread pencil

fitting to drive shaft
at head drive station and middle drive station

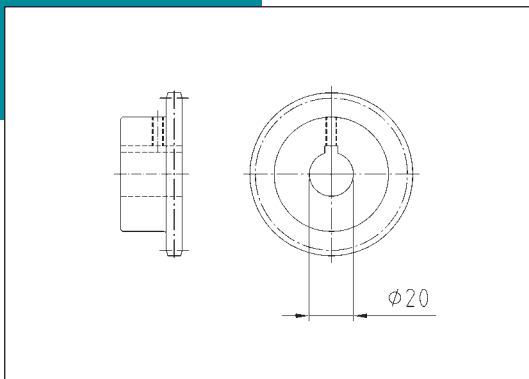

RO-flex 55/85/195

Chain sprocket 1/2 " -Z15	1 pcs.	102131
Chain sprocket 1/2 " -Z16	1 pcs.	102132
Chain sprocket 1/2 " -Z17	1 pcs.	102133
Chain sprocket 1/2 " -Z18	1 pcs.	102134
Chain sprocket 1/2 " -Z19	1 pcs.	102135
Chain sprocket 1/2 " -Z20	1 pcs.	102136
Chain sprocket 1/2 " -Z21	1 pcs.	102137
Chain sprocket 1/2 " -Z22	1 pcs.	102138

Steel galvanized
Drilling 20H7 with wedge lane, incl. thread pencil

fitting to gear motor S37 ...
at head drive station and middle drive station

Drive units

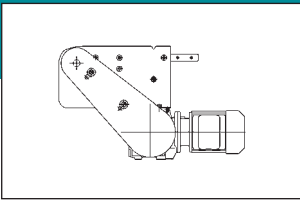

	Description	Unit	Art. No.
	<p>RO-flex 85</p> <p>Wheel bend drive station BA85-180 with motor</p> <p>Motor at the bottom</p> <p>In the extent of supply contain: motor, chain guard and attachment elements, pre-finished.</p> <p>Necessary chain length: 800 mm</p>	1 pcs.	102400
	<p>RO-flex 85</p> <p>Wheel bend drive station BA85-180 without motor</p> <p>Motor at the bottom</p> <p>In the extent of supply contain: driven shaft for gear motor SEW-SA37 ..., attachment elements.</p> <p>Necessary chain length: 800 mm</p>	1 pcs.	102400-oM

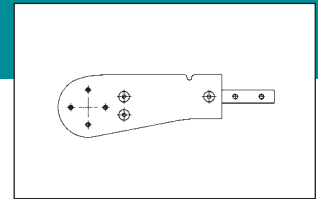

	Description	Unit	Art. No.
	<p>RO-flex 85</p> <p>Idler 180°</p> <p>PE/Steel galvanized incl. fastening elements</p> <p>Necessary chain length: 700 mm</p>	<p>1 pcs.</p>	<p>102501</p>
	<p>RO-flex 85</p> <p>Idler 90°</p> <p>PE/Steel galvanized incl. fastening elements</p> <p>Necessary chain length: 480 mm</p>	<p>1 pcs.</p>	<p>102630</p>
	<p>RO-flex 85</p> <p>Idler 180° with longer shaft, at right</p> <p>PE/Steel galvanized incl. fastening elements</p> <p>Can be used for drive or idler.</p> <p>Necessary chain length: 700 mm</p>	<p>1 pcs.</p>	<p>102650</p>

Idler units

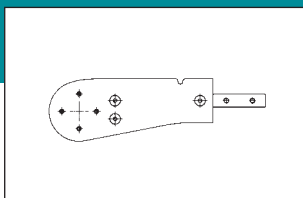

	Description	Unit	Art. No.
	<p>RO-flex 85</p> <p>Idler 180° with longer shaft, at left</p> <p>PE/Steel galvanized incl. fastening elements</p> <p>Can be used for drive or idler.</p> <p>Necessary chain length: 700 mm</p>	1 pcs.	102651

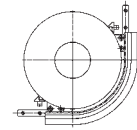

	Description	Unit	Art. No.
	<p>RO-flex 85</p> <p>Wheel bend 30°</p> <p>Aluminium/PC and Steel galvanized incl. fastening elements</p> <p>Necessary chain length: 570 mm Necessary guide rail: 600 mm</p>	1 pcs.	104001
	<p>RO-flex 85</p> <p>Wheel bend 45°</p> <p>Aluminium/PC and Steel galvanized incl. fastening elements</p> <p>Necessary chain length: 675 mm Necessary guide rail: 715 mm</p>	1 pcs.	104002
	<p>RO-flex 85</p> <p>Wheel bend 60°</p> <p>Aluminium/PC and Steel galvanized incl. fastening elements</p> <p>Necessary chain length: 780 mm Necessary guide rail: 835 mm</p>	1 pcs.	104003

Wheel bends

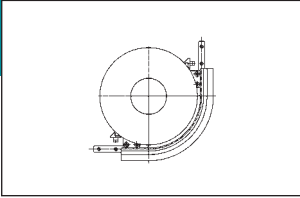

	Description	Unit	Art. No.
	<p>RO-flex 85</p> <p>Wheel bend 90°</p> <p>Aluminium/PC and Steel galvanized incl. fastening elements</p> <p>Necessary chain length: 990 mm Necessary guide rail: 1.070 mm</p>	1 pcs.	104004
	<p>RO-flex 85</p> <p>Wheel bend 180°</p> <p>Aluminium/PC and Steel galvanized incl. fastening elements</p> <p>Necessary chain length: 1.615 mm Necessary guide rail: 1.775 mm</p>	1 pcs.	104005

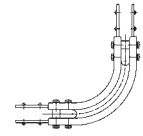

	Description	Unit	Art. No.
	<p>RO-flex 85</p> <p>Horizontal bend 15°</p> <p>PE/steel galvanized, incl. fastening elements Radius R= 200 mm</p> <p>Necessary chain length: 470 mm</p>	<p>1 pcs.</p>	<p>103051</p>
	<p>RO-flex 85</p> <p>Horizontal bend 30°</p> <p>PE/steel galvanized, incl. fastening elements Radius R= 200 mm</p> <p>Necessary chain length: 570 mm</p>	<p>1 pcs.</p>	<p>103052</p>
	<p>RO-flex 85</p> <p>Horizontal bend 45°</p> <p>PE/steel galvanized, incl. fastening elements Radius R= 200 mm</p> <p>Necessary chain length: 675 mm</p>	<p>1 pcs.</p>	<p>103053</p>

Horizontal bends

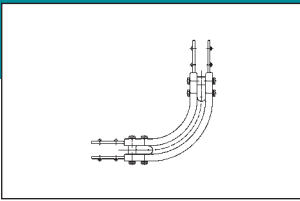

	Description	Unit	Art. No.
	<p>RO-flex 85</p> <p>Horizontal bend 60°</p> <p>PE/steel galvanized, incl. fastening elements Radius R= 200 mm</p> <p>Necessary chain length: 780 mm</p>	1 pcs.	103054
	<p>RO-flex 85</p> <p>Horizontal bend 90°</p> <p>PE/steel galvanized, incl. fastening elements Radius R= 200 mm</p> <p>Necessary chain length: 990 mm</p>	1 pcs.	103055
	<p>RO-flex 85</p> <p>Horizontal bend 180°</p> <p>PE/steel galvanized, incl. fastening elements Radius R= 200 mm</p> <p>Necessary chain length: 1.615 mm</p>	1 pcs.	103056

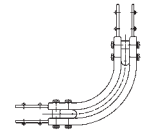

	Description	Unit	Art. No.
	<p>RO-flex 85/195</p> <p>Connecting strip E 20/5x140</p> <p>Stainless steel 1.4301 For the direct join of bends.</p> <p>Replace the premounted strips by the strips 101607. Reuse disassembled screws.</p>	1 pcs.	101607
	<p>RO-flex 85</p> <p>Horizontal bend 15°</p> <p>PE/steel galvanized, incl. fastening elements Radius R= 500 mm</p> <p>Necessary chain length: 620 mm</p>	1 pcs.	103131
	<p>RO-flex 85</p> <p>Horizontal bend 30°</p> <p>PE/steel galvanized, incl. fastening elements Radius R= 500 mm</p> <p>Necessary chain length: 885 mm</p>	1 pcs.	103132

Horizontal bends

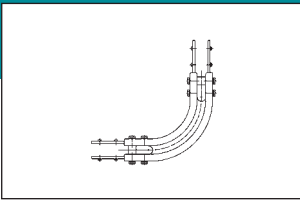

	Description	Unit	Art. No.
	<p>RO-flex 85</p> <p>Horizontal bend 45°</p> <p>PE/steel galvanized, incl. fastening elements Radius R= 500 mm</p> <p>Necessary chain length: 1.145 mm</p>	1 pcs.	103133
	<p>RO-flex 85</p> <p>Horizontal bend 60°</p> <p>PE/steel galvanized, incl. fastening elements Radius R= 500 mm</p> <p>Necessary chain length: 1.410 mm</p>	1 pcs.	103134
	<p>RO-flex 85</p> <p>Horizontal bend 90°</p> <p>PE/steel galvanized, incl. fastening elements Radius R= 500 mm</p> <p>Necessary chain length: 1.930 mm</p>	1 pcs.	103135

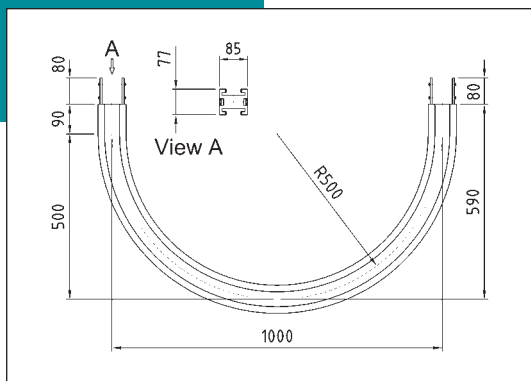
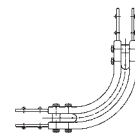

Description

Unit

Art. No.

RO-flex 85

Horizontal bend 180°

1 pcs.

103136

PE/steel galvanized, incl. fastening elements
Radius R= 500 mm

Necessary chain length: 3.500 mm

Vertical bends

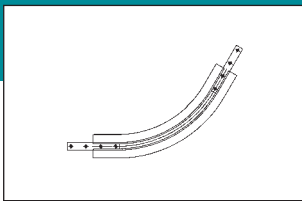

	Description	Unit	Art. No.
	<p>RO-flex 85</p> <p>Vertical bend 5°</p> <p>Aluminium, incl. fastening elements Radius R= 400 mm</p> <p>Necessary chain length: 430 mm Necessary guide rail: 860 mm</p>	1 pcs.	103501
	<p>RO-flex 85</p> <p>Vertical bend 10°</p> <p>Aluminium, incl. fastening elements Radius R= 400 mm</p> <p>Necessary chain length: 500 mm Necessary guide rail: 1.000 mm</p>	1 pcs.	103502
	<p>RO-flex 85</p> <p>Vertical bend 15°</p> <p>Aluminium, incl. fastening elements Radius R= 400 mm</p> <p>Necessary chain length: 570 mm Necessary guide rail: 1.140 mm</p>	1 pcs.	103503

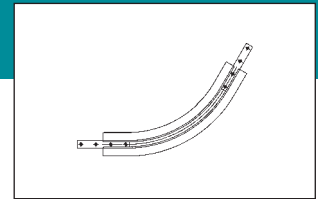

	Description	Unit	Art. No.
	<p>RO-flex 85</p> <p>Vertical bend 30°</p> <p>Aluminium, incl. fastening elements Radius R= 400 mm</p> <p>Necessary chain length: 780 mm Necessary guide rail: 1.560 mm</p>	1 pcs.	103504
	<p>RO-flex 85</p> <p>Vertical bend 45°</p> <p>Aluminium, incl. fastening elements Radius R= 400 mm</p> <p>Necessary chain length: 990 mm Necessary guide rail: 1.980 mm</p>	1 pcs.	103505
	<p>RO-flex 85</p> <p>Vertical bend 60°</p> <p>Aluminium, incl. fastening elements Radius R= 400 mm</p> <p>Necessary chain length: 1.200 mm Necessary guide rail: 2.400 mm</p>	1 pcs.	103506

Vertical bends

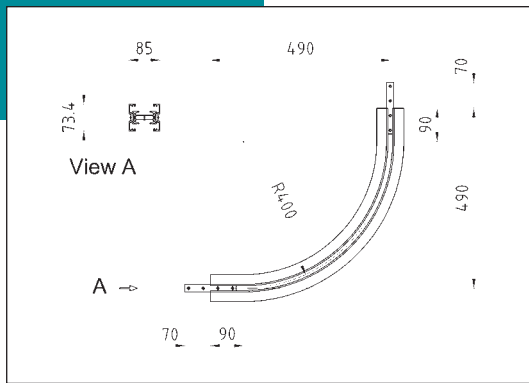
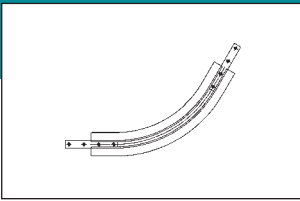

Description

Unit

Art. No.

RO-flex 85

Vertical bend 90°

1 pcs.

103507

Aluminium, incl. fastening elements
Radius R= 400 mm

Necessary chain length: 1.620 mm
Necessary guide rail: 3.240 mm

Content RO-flex 195 ALU

Chassis	Page 55
Chain	Page 58
Drive units	Page 61
Idler units	Page 64
Horizontal bends	Page 65
Vertical bends	Page 67
Supports	Page 72
Side guides	Page 86
Accessories, general	Page 105

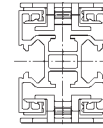

	Description	Unit	Art. No.
	<p>RO-flex 195</p> <p>Chassis profile 6m 195x76.5-F25E</p> <p>Aluminium anodized</p> <p>Length = 6.000 mm</p>	1 pcs.	201535
	<p>RO-flex 195</p> <p>Chassis profile cutting out 195x76.5-F25E</p> <p>Aluminium anodized</p> <p>By order indicate wished length (max. 6.000 mm). e.g.: length= 4.650 mm= Art. No. 201540-L4650</p>	1 pcs.	201540-L
	<p>RO-flex 55/85/195</p> <p>Slide rail white 6m 10x14W</p> <p>Superfrice</p> <p>Length = 6.000 mm</p>	1 pcs.	101001

Chassis

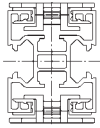

	Description	Unit	Art. No.
	<p>RO-flex 55/85/195</p> <p>Slide rail grey 6m 10x14G</p> <p>HDPE grey</p> <p>Length = 6.000 mm</p>	1 pcs.	101015
	<p>RO-flex 55/85/195</p> <p>Cylinder screw M4x8-PA</p> <p>PA 6 white</p> <p>for the fixing of the guide rail on the chassis profil</p>	100 pcs.	101050
	<p>RO-flex 55/85/195</p> <p>Connecting strip outside</p> <p>Steel galvanized incl. 4 thread pins</p>	1 pcs.	101003

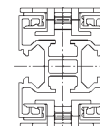

	Description	Unit	Art. No.
	<p>RO-flex 55/85/195</p> <p>Cover strip for chassis profile C20x3-PP</p> <p>Polypropylen</p> <p>Length = 3.000 mm</p>	<p>1 pcs.</p>	<p>105016</p>
	<p>RO-flex 85/195</p> <p>Tool MW85/195</p> <p>PE/Steel galvanized</p> <p>for mounting of guide rail</p>	<p>1 pcs.</p>	<p>101030</p>

Chain

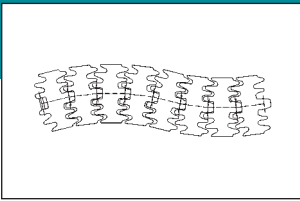

	Description	Unit	Art. No.
	<p>RO-flex 195</p> <p>Chain RT195/4</p> <p>POM white Length approx. 5 m</p>	1 pcs.	201850
	<p>RO-flex 195</p> <p>Chain link RT195/4</p> <p>POM white Single link, incl. bolt</p>	1 pcs.	201851
	<p>RO-flex 195</p> <p>Chain bolt 195/4-8x54</p> <p>Stainless steel 1.4301</p>	100 pcs.	201845

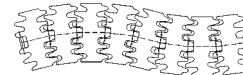

	Description	Unit	Art. No.
	<p>RO-flex 195</p> <p>Chain with strip RT195/4-H40-MA</p> <p>POM white Length approx. 5 m By order indicate strip distance.</p> <p>Example: every 6th link with strip = Art. No. 201870-MA6</p>	1 pcs.	201870-MA
	<p>RO-flex 195</p> <p>Chain link with strip RT195/4-H40</p> <p>POM white Single link, incl. bolt</p>	1 pcs.	201871
	<p>RO-flex 195</p> <p>Chain with adhesiv coating RT195/4-white-MA</p> <p>POM white Length approx. 5 m By order indicate strip distance.</p> <p>Example: every 6th link with strip = Art. No. 201855-MA6</p>	1 pcs.	201855-MA

Chain

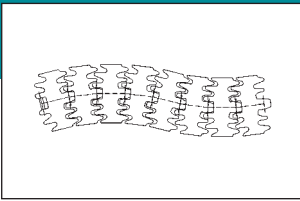

	Description	Unit	Art. No.
	<p>RO-flex 195</p> <p>Chain link with adhesiv coating RT195/4-white</p> <p>POM white Single link, incl. bolt</p>	1 pcs.	201856
	<p>RO-flex 195</p> <p>Chain with adhesiv coating RT195/4-green-MA</p> <p>POM white Length approx. 5 m By order indicate strip distance.</p> <p>Example: every 6th link with strip = Art. No. 201860-MA6</p>	1 pcs.	201860-MA
	<p>RO-flex 195</p> <p>Chain link with adhesiv coating RT195/4-green</p> <p>POM white Single link, incl. bolt</p>	1 pcs.	201861

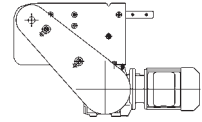

	Description	Unit	Art. No.
	<p>RO-flex 195</p> <p>Head drive station KA195-R with motor</p> <p>Motor on the right</p> <p>In the extent of supply contain: motor, sprockets, rolling chain, chain guard, attachment elements, pre-finished.</p> <p>Necessary chain length: 950 mm</p>	<p>1 pcs.</p>	<p>202001</p>
	<p>RO-flex 195</p> <p>Head drive station KA195-R without motor</p> <p>Motor on the right</p> <p>In the extent of supply contain: motor plate for gear motor SEW-S37 ..., chain guard, attachment elements.</p> <p>Necessary chain length: 950 mm</p>	<p>1 pcs.</p>	<p>202001-oM</p>
	<p>RO-flex 195</p> <p>Head drive station KA195-L with motor</p> <p>Motor on the left</p> <p>In the extent of supply contain: motor, sprockets, rolling chain, chain guard, attachment elements, pre-finished.</p> <p>Necessary chain length: 950 mm</p>	<p>1 pcs.</p>	<p>202002</p>

Drive units

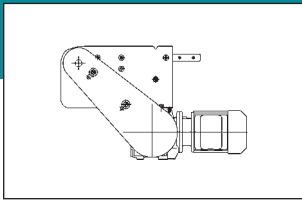

	Description	Unit	Art. No.
	<p>RO-flex 195</p> <p>Head drive station KA195-L without motor</p> <p>Motor on the left</p> <p>In the extent of supply contain: motor plate for gear motor SEW-S37 ..., chain guard, attachment elements.</p> <p>Necessary chain length: 950 mm</p>	1 pcs.	202002-oM
	<p>RO-flex 85/195</p> <p>Roller chain 1/2" black RK-08B-1-78E</p> <p>Endless 965.2 mm incl. coupler link</p>	1 pcs.	900900

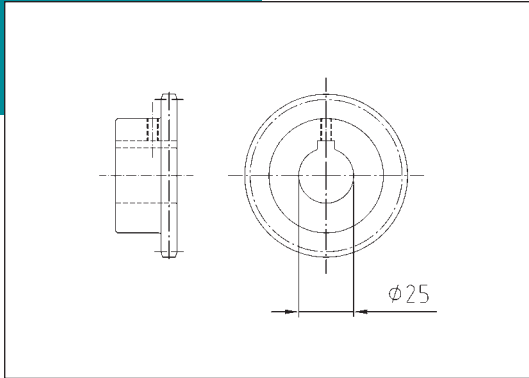
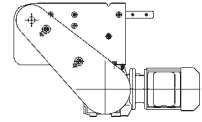

Description

Unit

Art. No.

RO-flex 85/195

Chain sprocket 1/2 " -Z15

1 pcs.

102111

Chain sprocket 1/2 " -Z16

1 pcs.

102112

Chain sprocket 1/2 " -Z17

1 pcs.

102113

Chain sprocket 1/2 " -Z18

1 pcs.

102114

Chain sprocket 1/2 " -Z19

1 pcs.

102115

Chain sprocket 1/2 " -Z20

1 pcs.

102116

Chain sprocket 1/2 " -Z21

1 pcs.

102117

Chain sprocket 1/2 " -Z22

1 pcs.

102118

Steel galvanized
Drilling 25H7 with wedge lane, incl. thread pencil

fitting to drive shaft
at head drive station

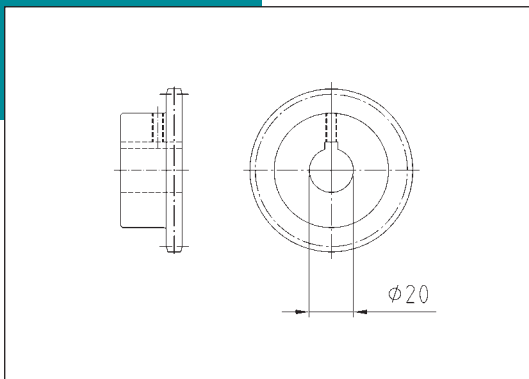

RO-flex 55/85/195

Chain sprocket 1/2 " -Z15

1 pcs.

102131

Chain sprocket 1/2 " -Z16

1 pcs.

102132

Chain sprocket 1/2 " -Z17

1 pcs.

102133

Chain sprocket 1/2 " -Z18

1 pcs.

102134

Chain sprocket 1/2 " -Z19

1 pcs.

102135

Chain sprocket 1/2 " -Z20

1 pcs.

102136

Chain sprocket 1/2 " -Z21

1 pcs.

102137

Chain sprocket 1/2 " -Z22

1 pcs.

102138

Steel galvanized
Drilling 20H7 with wedge lane, incl. thread pencil

fitting to gear motor S37 ...
at head drive station

Idler units

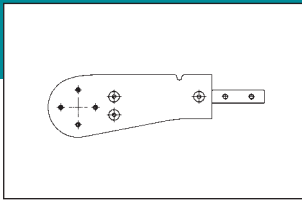

	Description	Unit	Art. No.
	<p>RO-flex 195</p> <p>Idler 180°</p> <p>PE/Steel galvanized incl. fastening elements</p> <p>Necessary chain length: 700 mm</p>	1 pcs.	202501
	<p>RO-flex 195</p> <p>Idler 180° with longer shaft, at right</p> <p>PE/Steel galvanized incl. fastening elements</p> <p>Can be used for drive or idler.</p> <p>Necessary chain length: 700 mm</p>	1 pcs.	202510
	<p>RO-flex 195</p> <p>Idler 180° with longer shaft, at left</p> <p>PE/Steel galvanized incl. fastening elements</p> <p>Can be used for drive or idler.</p> <p>Necessary chain length: 700 mm</p>	1 pcs.	202511

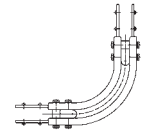

	Description	Unit	Art. No.
	<p>RO-flex 195</p> <p>Horizontal bend 30°</p> <p>PE/steel galvanized, incl. fastening elements Radius R= 600 mm</p> <p>Necessary chain length: 990 mm</p>	<p>1 pcs.</p>	<p>203151</p>
	<p>RO-flex 195</p> <p>Horizontal bend 45°</p> <p>PE/steel galvanized, incl. fastening elements Radius R= 600 mm</p> <p>Necessary chain length: 1.300 mm</p>	<p>1 pcs.</p>	<p>203152</p>
	<p>RO-flex 195</p> <p>Horizontal bend 60°</p> <p>PE/steel galvanized, incl. fastening elements Radius R= 600 mm</p> <p>Necessary chain length: 1.620 mm</p>	<p>1 pcs.</p>	<p>203153</p>

Horizontal bends

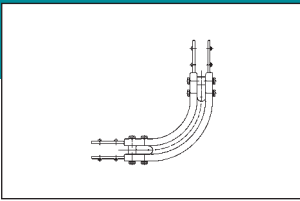

	Description	Unit	Art. No.
	<p>RO-flex 195</p> <p>Horizontal bend 90°</p> <p>PE/steel galvanized, incl. fastening elements Radius R= 600 mm</p> <p>Necessary chain length: 2.250 mm</p>	1 pcs.	203154
	<p>RO-flex 195</p> <p>Horizontal bend 180°</p> <p>PE/steel galvanized, incl. fastening elements Radius R= 600 mm</p> <p>Necessary chain length: 4.140 mm</p>	1 pcs.	203155
	<p>RO-flex 85/195</p> <p>Connecting strip E 20/5x140</p> <p>Stainless steel 1.4301 For the direct join of bends.</p>	1 pcs.	101607



	Description	Unit	Art. No.
	<p>RO-flex 195</p> <p>Vertical bend 5°</p> <p>Aluminium, incl. fastening elements Radius R= 600 mm</p> <p>Necessary chain length: 465 mm Necessary guide rail: 1.395 mm</p>	1 pcs.	203501
	<p>RO-flex 195</p> <p>Vertical bend 10°</p> <p>Aluminium, incl. fastening elements Radius R= 600 mm</p> <p>Necessary chain length: 570 mm Necessary guide rail: 1.710 mm</p>	1 pcs.	203502
	<p>RO-flex 195</p> <p>Vertical bend 15°</p> <p>Aluminium, incl. fastening elements Radius R= 600 mm</p> <p>Necessary chain length: 675 mm Necessary guide rail: 2.025 mm</p>	1 pcs.	203503

Vertical bends

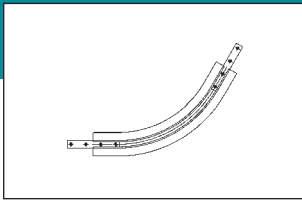

	Description	Unit	Art. No.
	<p>RO-flex 195</p> <p>Vertical bend 30°</p> <p>Aluminium, incl. fastening elements Radius R= 600 mm</p> <p>Necessary chain length: 990 mm Necessary guide rail: 2.970 mm</p>	1 pcs.	203504
	<p>RO-flex 195</p> <p>Vertical bend 45°</p> <p>Aluminium, incl. fastening elements Radius R= 600 mm</p> <p>Necessary chain length: 1.300 mm Necessary guide rail: 3.900 mm</p>	1 pcs.	203505
	<p>RO-flex 195</p> <p>Vertical bend 60°</p> <p>Aluminium, incl. fastening elements Radius R= 600 mm</p> <p>Necessary chain length: 1.620 mm Necessary guide rail: 4.860 mm</p>	1 pcs.	203506

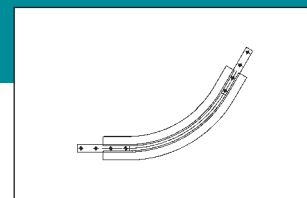

	Description	Unit	Art. No.
	<p>RO-flex 195</p> <p>Vertical bend 90°</p> <p>Aluminium, incl. fastening elements Radius R= 600 mm</p> <p>Necessary chain length: 2.250 mm Necessary guide rail: 6.750 mm</p>	1 pcs.	203507

Content Accessories ALU

Supports

Page 72

Side guides

Page 86

Accessories, general

Page 105

Supports

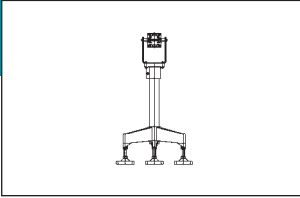

Support possibility System R60 (Tube ø60mm, galvanized)

Support height H= 500-max.2000mm

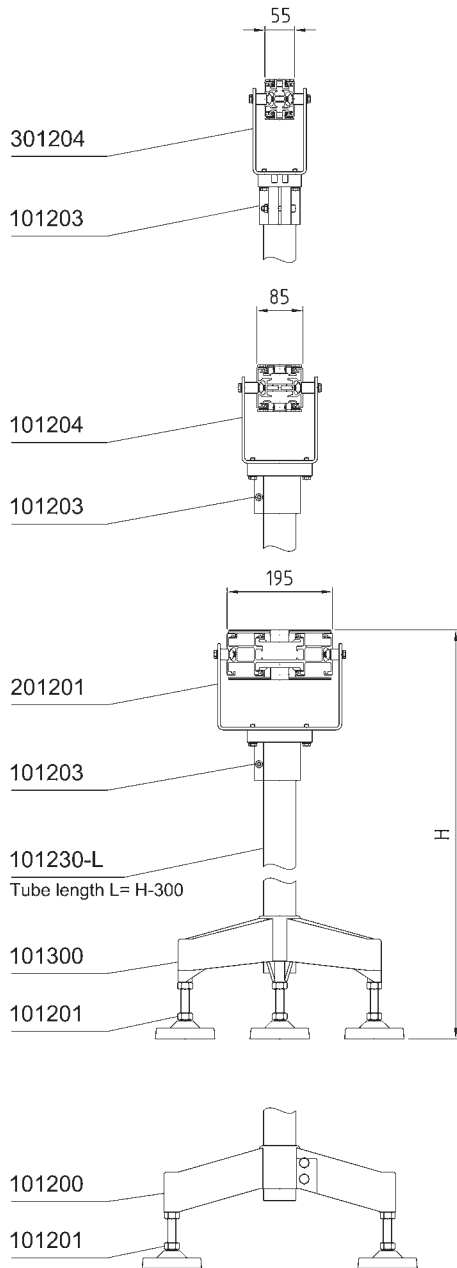

Support from head drive station

RO-flex-55

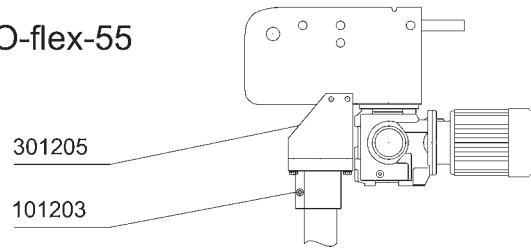

RO-flex-85

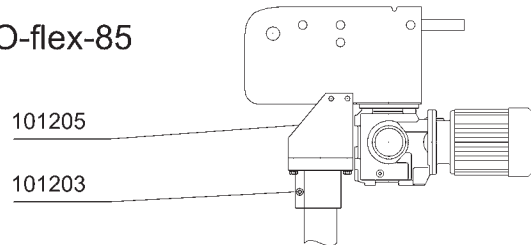

RO-flex-195

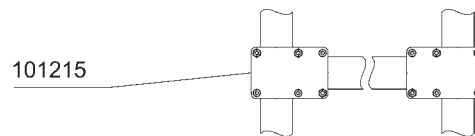
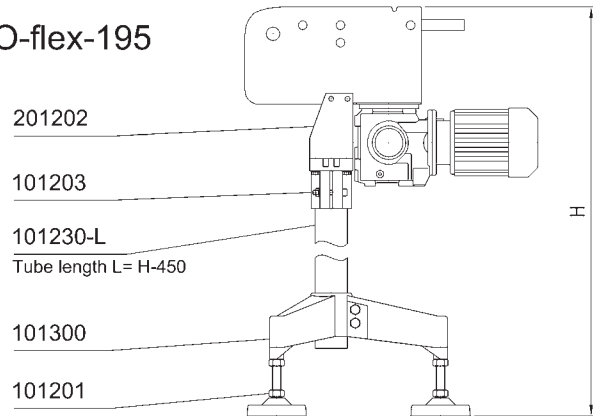

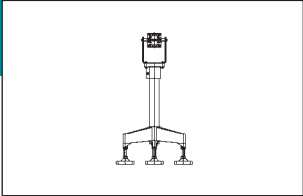

	Description	Unit	Art. No.
	<p>RO-flex 55/85/195</p> <p>Support tube cutting out R60-galvanized</p> <p>Steel galvanized</p> <p>By order indicate wished length.</p> <p>Example for chassis support, inlet level H= 900 mm: with L= H- 300; L= 900- 300= 600 mm =Art. No. 101230-L600</p>	1 pcs.	101230-L
	<p>RO-flex 55/85/195</p> <p>2-legs support R60-ST2</p> <p>PA 6 black incl. fastening elements</p>	1 pcs.	101200
	<p>RO-flex 55/85/195</p> <p>3-legs support R60-ST3</p> <p>PA 6 black incl. fastening elements</p>	1 pcs.	101300

Supports

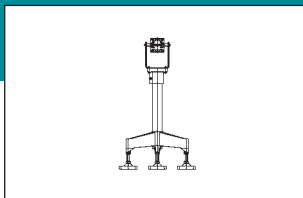

	Description	Unit	Art. No.
	<p>RO-flex 55/85/195</p> <p>Adjustable foot 110/M16-160</p> <p>PA 6/Steel galvanized incl. fastening elements</p>	1 pcs.	101201
	<p>RO-flex 55/85/195</p> <p>Clamp piece R60-KL</p> <p>PA 6 black incl. fastening elements</p>	1 pcs.	101215
	<p>RO-flex 55/85/195</p> <p>Header R60-KO</p> <p>PA 6 black incl. fastening elements</p>	1 pcs.	101203

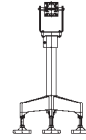

	Description	Unit	Art. No.
	<p>RO-flex 55</p> <p>Chassis supporting yoke R60-CH55-assembly kit</p> <p>Steel galvanized incl. fastening elements</p>	<p>1 pcs.</p>	<p>301204</p>
	<p>RO-flex 55</p> <p>Head drive supporting yoke R60-KA55-assembly kit</p> <p>Steel galvanized incl. fastening elements</p>	<p>1 pcs.</p>	<p>301205</p>
	<p>RO-flex 85</p> <p>Chassis supporting yoke R60-CH85-assembly kit</p> <p>Steel galvanized incl. fastening elements</p>	<p>1 pcs.</p>	<p>101204</p>

Supports

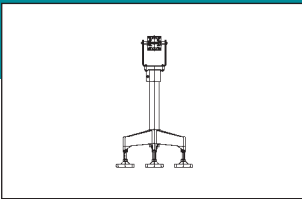

	Description	Unit	Art. No.
	<p>RO-flex 85</p> <p>Head drive supporting yoke R60-KA85-assembly kit</p> <p>Steel galvanized incl. fastening elements</p>	1 pcs.	101205
	<p>RO-flex 195</p> <p>Chassis supporting yoke R60-CH195-assembly kit</p> <p>Steel galvanized incl. fastening elements</p>	1 pcs.	201201
	<p>RO-flex 195</p> <p>Head drive supporting yoke R60-KA195-assembly kit</p> <p>Steel galvanized incl. fastening elements</p>	1 pcs.	201202

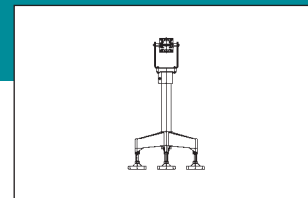

Support possibility System P50 (Profile 50x50mm)

Support height H= 350-max.1200mm

ex.: multiple support

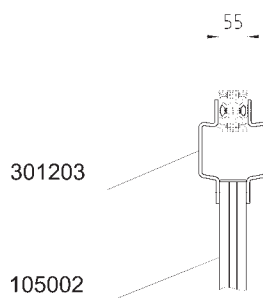

RO-flex-55

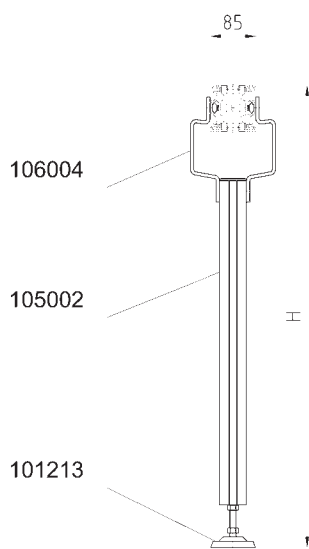
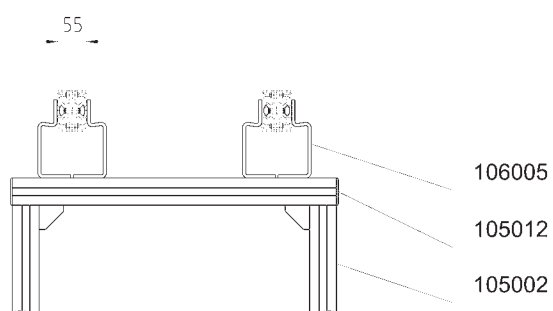

RO-flex-85

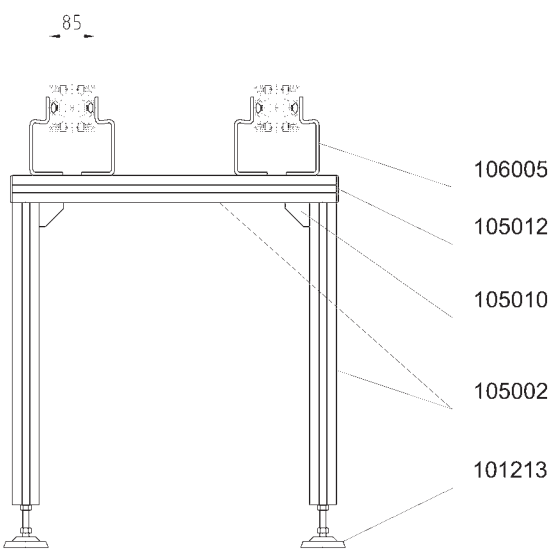

Supports

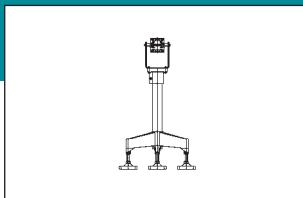

	Description	Unit	Art. No.
	<p>RO-flex 55/85</p> <p>Support 50x50 P50-AL</p> <p>Aluminium anodized</p> <p>Length = 6.000 mm</p>	1 pcs.	105002
	<p>RO-flex 55/85</p> <p>Adjustable foot 80/M12-100</p> <p>PA 6/Steel galvanized incl. fastening elements</p>	1 pcs.	101213
	<p>RO-flex 55/85</p> <p>Mounting bracket P50-L45/45/48-assembly kit</p> <p>Cast aluminium incl. fastening elements</p>	1 pcs.	105010

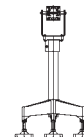

	Description	Unit	Art. No.
	<p>RO-flex 55/85</p> <p>End cap 50x50 P50</p> <p>PA 6 black</p>	1 pcs.	105012
	<p>RO-flex 55/85/195</p> <p>Cover strip</p> <p>Polypropylen grey</p> <p>Length = 6.000 mm</p>	1 pcs.	105013
	<p>RO-flex 55</p> <p>Chassis supporting yoke P50-I 55-assembly kit</p> <p>Steel galvanized incl. fastening elements</p>	1 pcs.	301203

Supports

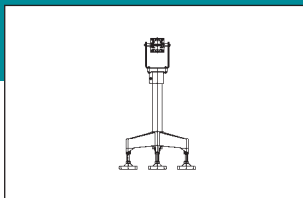

	Description	Unit	Art. No.
	<p>RO-flex 85</p> <p>Chassis supporting yoke P50-I 85-assembly kit</p> <p>Steel galvanized incl. fastening elements</p>	1 pcs.	106004
	<p>RO-flex 85</p> <p>Chassis supporting yoke P50-L 85-assembly kit</p> <p>Steel galvanized incl. fastening elements</p>	1 pcs.	106005

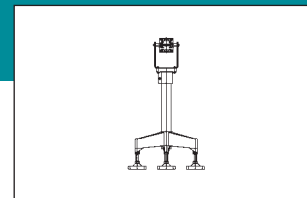

Support possibility System P100 (Profile 100x100mm)

Support height H= 250-max.4000mm

ex.: multiple support

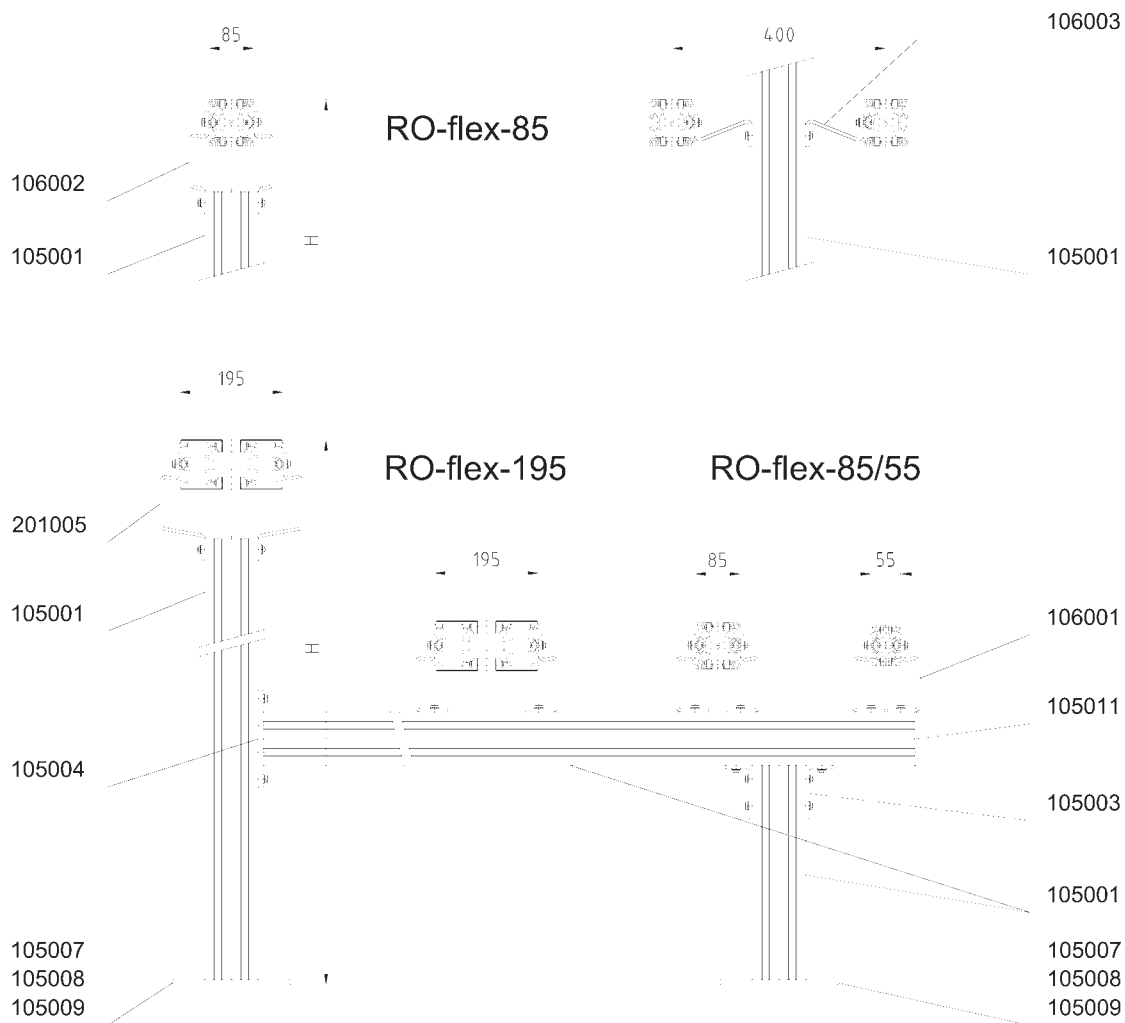

Supports

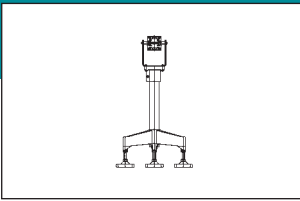

	Description	Unit	Art. No.
	<p>RO-flex 85/195</p> <p>Support 100x100 P100-AL</p> <p>Aluminium anodized</p> <p>Length = 6.000 mm</p>	1 pcs.	105001
	<p>RO-flex 85/195</p> <p>Foot plate 220x220</p> <p>Foot plate 350x350</p> <p>Foot plate 450x450</p> <p>Steel galvanized</p> <p>incl. fastening elements</p>	<p>1 pcs.</p> <p>1 pcs.</p> <p>1 pcs.</p>	<p>105007</p> <p>105008</p> <p>105009</p>
	<p>RO-flex 85/195</p> <p>Connecting angle P100-L100/50-assembly kit</p> <p>Aluminium anodized</p> <p>incl. fastening elements</p>	1 pcs.	105003

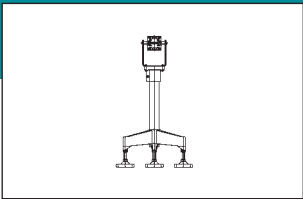

	Description	Unit	Art. No.
	<p>RO-flex 85/195</p> <p>Connecting plate P100-100/180-assembly kit</p> <p>Aluminium anodized incl. fastening elements</p>	1 pcs.	105004
	<p>RO-flex 85/195</p> <p>End cap 100x100 P100</p> <p>PA 6 black</p>	1 pcs.	105011
	<p>RO-flex 55/85/195</p> <p>Cover strip</p> <p>Polypropylen grey</p> <p>Length = 6.000 mm</p>	1 pcs.	105013

Supports

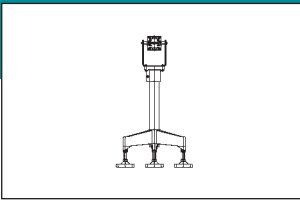

	Description	Unit	Art. No.
	<p>RO-flex 85</p> <p>Chassis supporting yoke P100-I 85-assembly kit</p> <p>Steel galvanized incl. fastening elements</p>	1 pcs.	106002
	<p>RO-flex 85/195</p> <p>Chassis supporting yoke P100-L 85/195-assembly kit</p> <p>Steel galvanized incl. fastening elements</p>	1 pcs.	106001
	<p>RO-flex 195</p> <p>Chassis supporting yoke P100-I 195-assembly kit</p> <p>Steel galvanized incl. fastening elements</p>	1 pcs.	201005

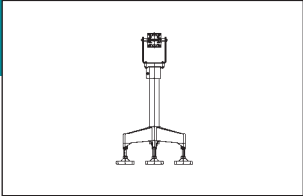

Description

Unit

Art. No.

RO-flex 85
Chassis supporting yoke
P100-Z 85-assembly kit

1 pcs.

106003

Steel galvanized
 incl. fastening elements

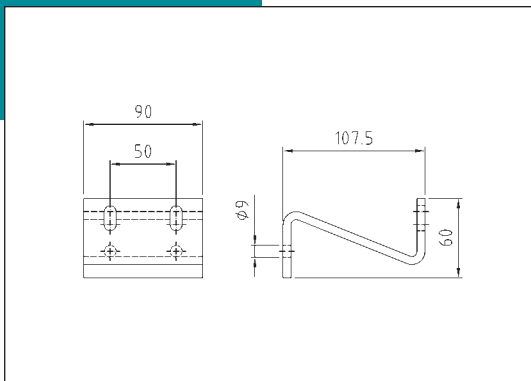

Side guides

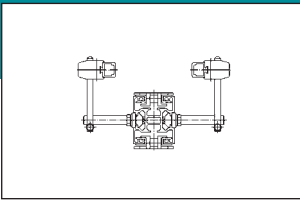

Side guide possibility System SF1

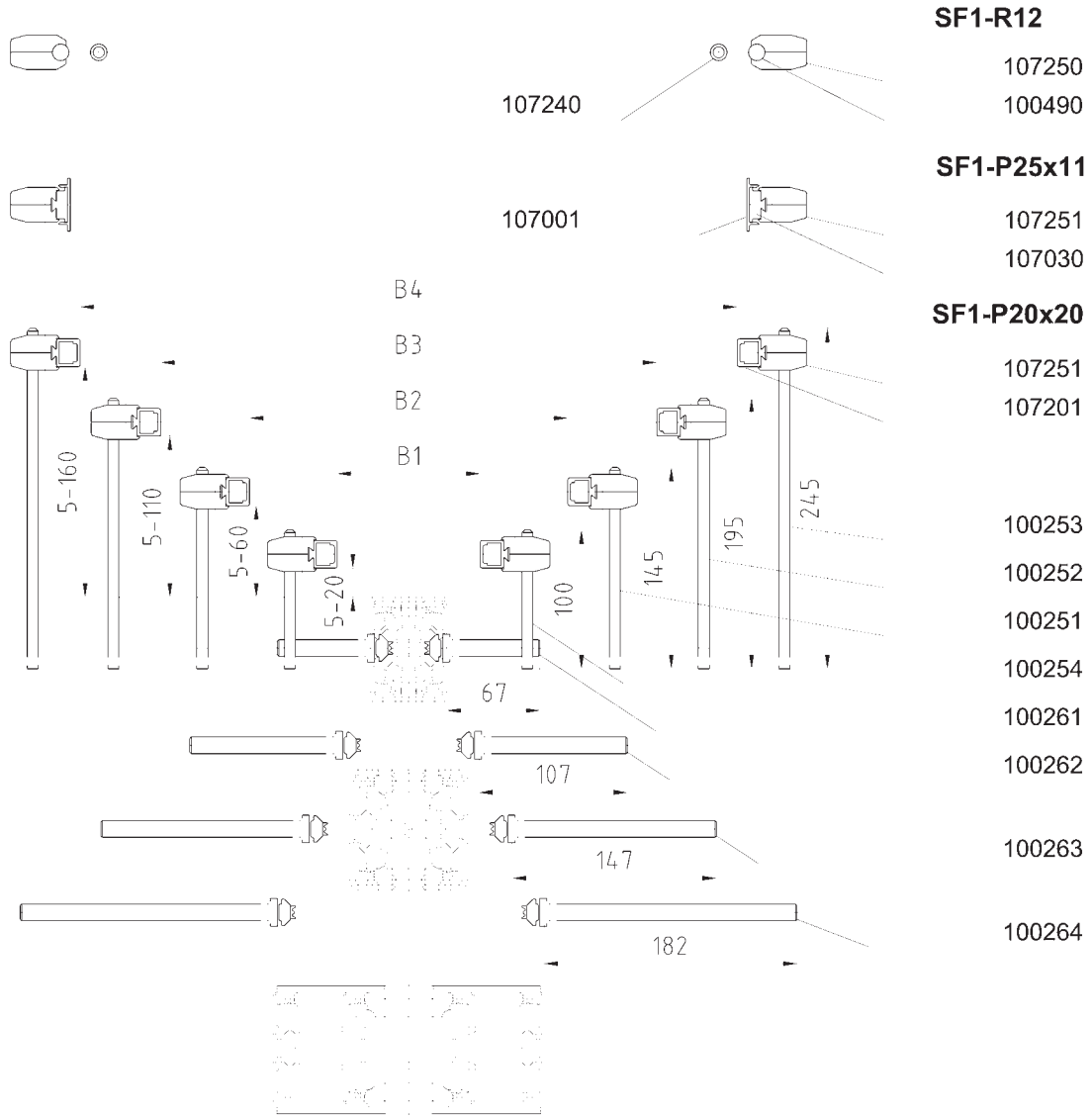

guidance width (mm)		RO-flex-55	RO-flex-85	RO-flex-195
B1		25 - 110	55 - 140	165 - 250
B2		-	55 - 220	165 - 330
B3		-	55 - 300 ×	165 - 410
B4		-	55 - 370 ×	165 - 480

✗ For product width B>250 provide product supports.

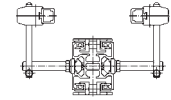

	Description	Unit	Art. No.
	RO-flex 55/85/195 Bracket SF1-12/70-assembly kit Steel galvanized incl. fastening elements	1 pcs.	100261
	RO-flex 85/195 Bracket SF1-12/110-assembly kit Steel galvanized incl. fastening elements	1 pcs.	100262
	RO-flex 85/195 Bracket SF1-12/150-assembly kit Steel galvanized incl. fastening elements	1 pcs.	100263

Side guides

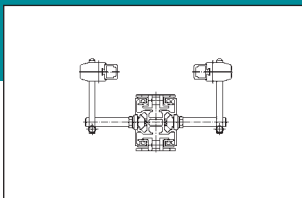

	Description	Unit	Art. No.
	<p>RO-flex 85/195</p> <p>Bracket SF1-12/185-assembly kit</p> <p>Steel galvanized incl. fastening elements</p>	1 pcs.	100264
	<p>RO-flex 55/85/195</p> <p>Clamp holder SF1-100</p> <p>Steel galvanized incl. fastening elements</p>	1 pcs.	100254
	<p>RO-flex 55/85/195</p> <p>Clamp holder SF1-145</p> <p>Steel galvanized incl. fastening elements</p>	1 pcs.	100251

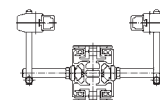

	Description	Unit	Art. No.
	<p>RO-flex 55/85/195</p> <p>Clamp holder SF1-195</p> <p>Steel galvanized incl. fastening elements</p>	1 pcs.	100252
	<p>RO-flex 55/85/195</p> <p>Clamp holder SF1-245</p> <p>Steel galvanized incl. fastening elements</p>	1 pcs.	100253

Side guides

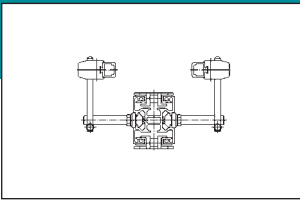

Side guide possibility System SF2

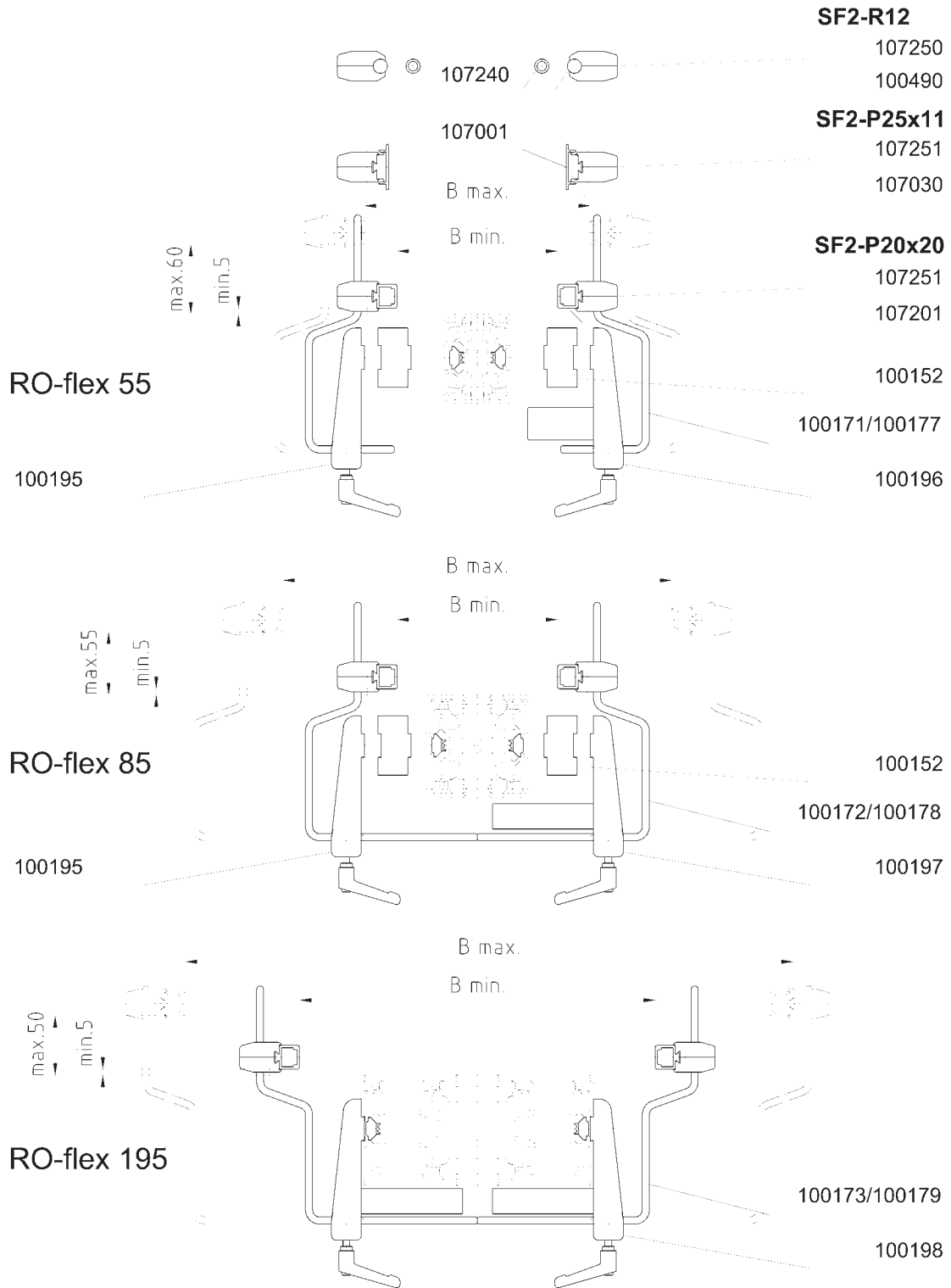

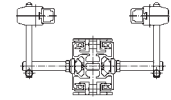

Side guide possibility System SF2

guidance width (mm):

Yoke typ:	Distanz 100152: number per side	RO-flex-55 B	RO-flex-85 B	RO-flex-195 B
Yoke K	without	11 - 70	41 - 100	151 - 210
with scale 100171	1 pcs.	61 - 120	91 - 150	201 - 260
without scale 100177	2 pcs.	-	141 - 200	251 - 310
Yoke M	without	-	41 - 240	151 - 350
with scale 100172	1 pcs.	-	91 - 290	201 - 400
without scale 100178	2 pcs.	-	151 - 340	251 - 450
Yoke L	without	-	205 - 405	315 - 515
with scale 100173	1 pcs.	-	255 - 455	265 - 565
without scale 100179	2 pcs.	-	315 - 505	415 - 615

For product width $B > 250$ provide product supports.

Assembly instruction: (only for RO-flex 85)

- For product width $B < 151$ mm bracket shall be moved for 40mm.
- For product width $B < 315$ mm bracket shall be moved for 40mm.

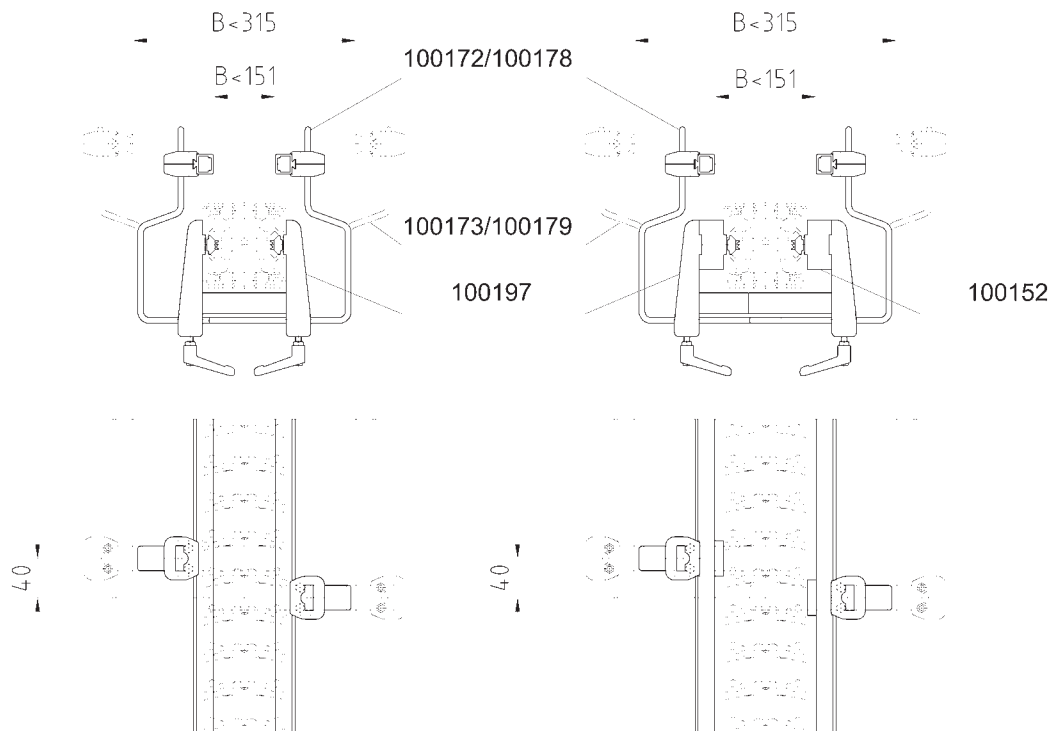

Side guides

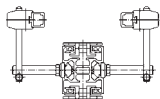

	Description	Unit	Art. No.
	<p>RO-flex 55</p> <p>Side guide holder SF2-55-assembly kit</p> <p>PA 6/Steel galvanized incl. fastening elements and protection</p>	1 pcs.	100196
	<p>RO-flex 85</p> <p>Side guide holder SF2-85-assembly kit</p> <p>PA 6/Steel galvanized incl. fastening elements and protection</p>	1 pcs.	100197
	<p>RO-flex 195</p> <p>Side guide holder SF2-195-assembly kit</p> <p>PA 6/Steel galvanized incl. fastening elements and protection</p>	1 pcs.	100198

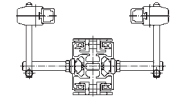

	Description	Unit	Art. No.
	<p>RO-flex 55/85/195</p> <p>Side guide holder SF2-0-assembly kit</p> <p>PA 6/Steel galvanized incl. fastening elements without protection</p>	1 pcs.	100195
	<p>RO-flex 55/85/195</p> <p>Spacer SF2-25</p> <p>PA 6 black</p>	1 pcs.	100152
	<p>RO-flex 55/85/195</p> <p>Short yoke SF2-K</p> <p>Steel galvanized</p>	1 pcs.	100177

Side guides

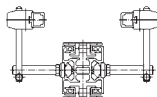

	Description	Unit	Art. No.
	<p>RO-flex 85/195</p> <p>Middle yoke SF2-M</p> <p>Steel galvanized</p>	1 pcs.	100178
	<p>RO-flex 85/195</p> <p>Long yoke SF2-L</p> <p>Steel galvanized</p>	1 pcs.	100179
	<p>RO-flex 55/85/195</p> <p>Short yoke with scale SF2-K+M</p> <p>Steel galvanized</p>	1 pcs.	100171

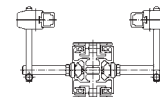

	Description	Unit	Art. No.
	<p>RO-flex 85/195</p> <p>Middle yoke with scale SF2-M+M</p> <p>Steel galvanized</p>	<p>1 pcs.</p>	<p>100172</p>
	<p>RO-flex 85/195</p> <p>Long yoke with scale SF2-L+M</p> <p>Steel galvanized</p>	<p>1 pcs.</p>	<p>100173</p>

Side guides

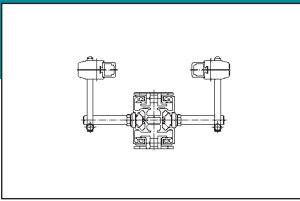

Side guide possibility System SF3

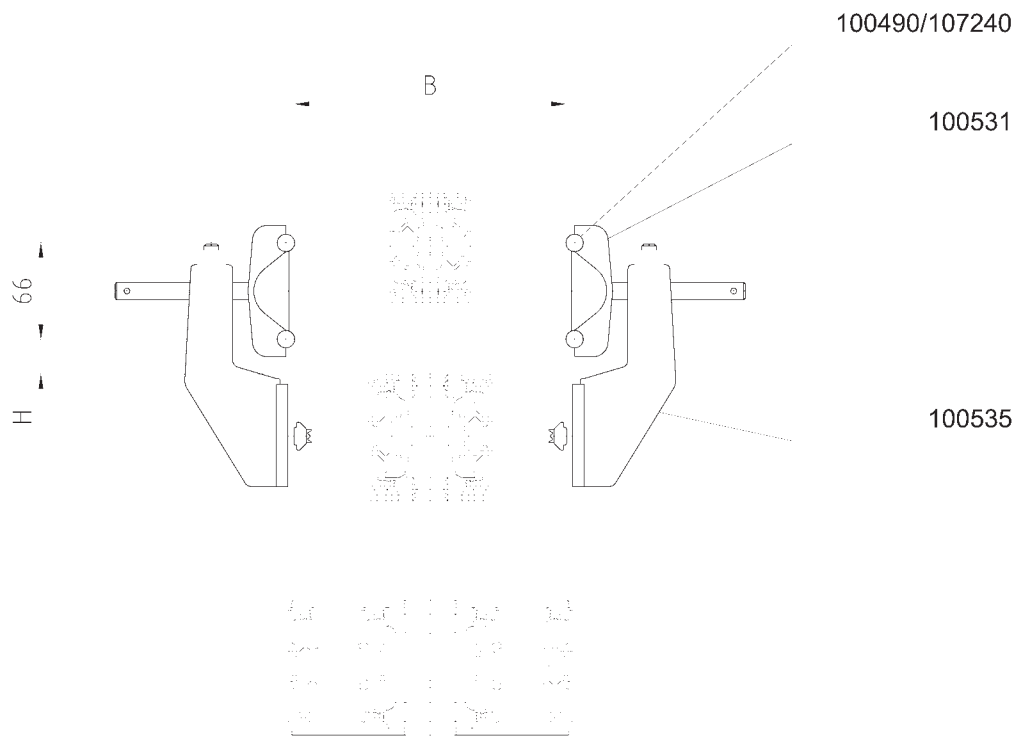

	RO-flex-55	RO-flex-85	RO-flex-195
guidance width B (mm)	0 - 80	0 - 110	85 - 220
Height H (mm)	29	24	23

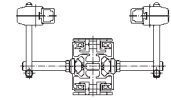

	Description	Unit	Art. No.
	<p>RO-flex 55/85/195</p> <p>Side guide holder SF3-assembly kit</p> <p>PA 6/Steel galvanized incl. fastening elements</p>	1 pcs.	100535
	<p>RO-flex 55/85/195</p> <p>Double clamp SF3</p> <p>PA 6/Stainless steel 1.4301</p>	1 pcs.	100531
	<p>RO-flex 55/85/195</p> <p>Guide profile $\varnothing 12$ R12</p> <p>Stainless steel 1.4301</p> <p>Length = 3.000 mm</p>	1 pcs.	100490

Side guides

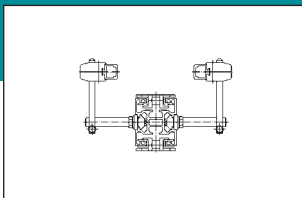

	Description	Unit	Art. No.
	<p>RO-flex 55/85/195</p> <p>Polymer coated guide profile R12-KU</p> <p>Stainless steel 1.4301/HDPE grey</p> <p>Length = 3.000 mm</p>	1 pcs.	107240
	<p>RO-flex 55/85/195</p> <p>End cap to guide profile R12-KU</p> <p>HDPE grey</p>	1 pcs.	107242
	<p>RO-flex 55/85/195</p> <p>Clamp to guide profile R12</p> <p>PA 6 black incl. fastening elements</p>	1 pcs.	107250

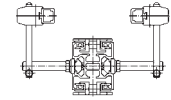

	Description	Unit	Art. No.
	<p>RO-flex 55/85/195</p> <p>Connecting sleeve R12-assembly kit</p> <p>Stainless steel 1.4301 incl. fastening elements</p>	1 pcs.	107252
	<p>RO-flex 55/85/195</p> <p>Guide profile 20x20 P20x20-AL</p> <p>Aluminium anodized</p> <p>Length = 6.000 mm</p>	1 pcs.	107201
	<p>RO-flex 55/85/195</p> <p>Guide profile connector P20x20</p> <p>PA 6 black</p>	1 pcs.	107211

Side guides

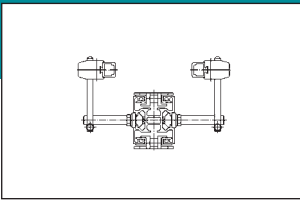

	Description	Unit	Art. No.
	<p>RO-flex 55/85/195</p> <p>End cap P20x20</p> <p>PA 6 black</p>	1 pcs.	107212
	<p>RO-flex 55/85/195</p> <p>Inlet wedge type A P20x20</p> <p>PA 6 black</p>	1 pcs.	107213
	<p>RO-flex 55/85/195</p> <p>Inlet wedge type B P20x20</p> <p>PA 6 black</p>	1 pcs.	107214

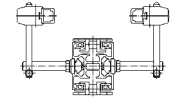

	Description	Unit	Art. No.
	<p>RO-flex 55/85/195</p> <p>Inlet wedge type B short P20x20</p> <p>PA 6 black</p>	1 pcs.	107215
	<p>RO-flex 55/85/195</p> <p>Clamp to guide profile P20x20</p> <p>PA 6 black incl. fastening elements</p>	1 pcs.	107251
	<p>RO-flex 55/85/195</p> <p>Guide profile 25x11 P25x11-AL</p> <p>Aluminium anodized</p> <p>Length = 6.000 mm</p>	1 pcs.	107030

Side guides

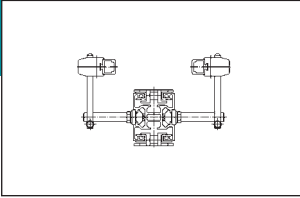

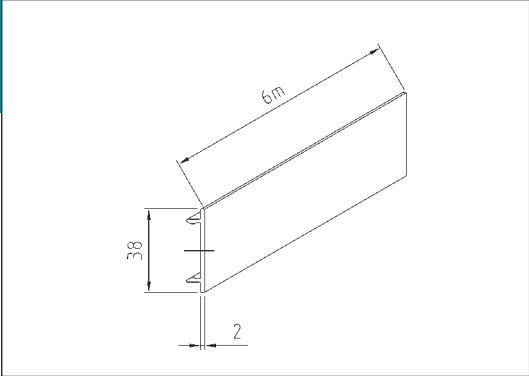
Description	Unit	Art. No.
 <p data-bbox="683 416 863 443">RO-flex 55/85/195</p> <p data-bbox="683 472 951 544">Protector to guide profile P25x11</p> <p data-bbox="683 573 772 600">RABS grey</p> <p data-bbox="683 624 839 651">Length = 6.000 mm</p>	1 pcs.	107001

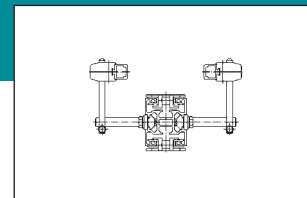

Support product RO-flex 85

Product width B >250 - 400mm

SYSTEM 85-R12

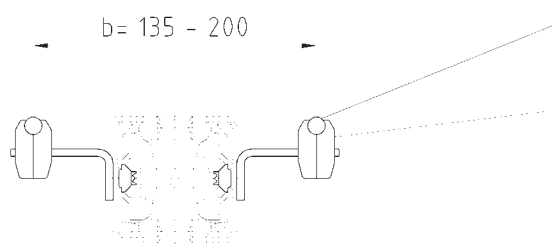

100490/107240

107250

100545

Product width B >300 - 500mm

SYSTEM 85-P20x20

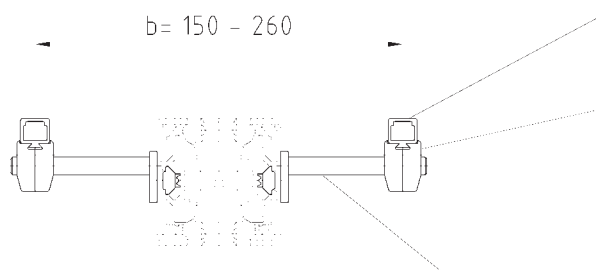

107201

107251

100280

Side guides

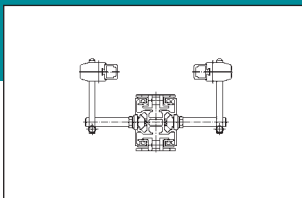

	Description	Unit	Art. No.
	<p>RO-flex 85</p> <p>Bracket for produkt support R12-assembly kit</p> <p>Steel galvanized incl. fastening elements</p>	1 pcs.	100545
	<p>RO-flex 85</p> <p>Bracket for produkt support P20x20-assembly kit</p> <p>Steel galvanized incl. fastening elements</p>	1 pcs.	100280

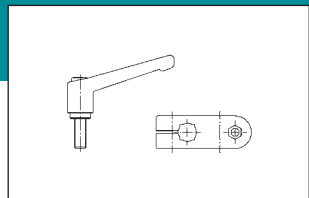

	Description	Unit	Art. No.
	RO-flex 55/85/195 Screw nut M5x20 Steel galvanized	100 pcs.	105023
	RO-flex 55/85/195 Screw nut M6x20 Steel galvanized	100 pcs.	105022
	RO-flex 55/85/195 Screw nut M8x20 Steel galvanized	100 pcs.	105006

Accessories, general

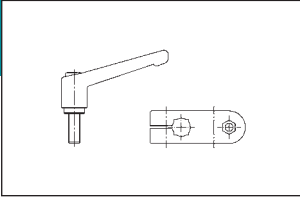

	Description	Unit	Art. No.
	RO-flex 55/85/195 Screw nut M10x30 Steel galvanized	100 pcs.	105021
	RO-flex 55/85/195 Screw nut M12x30 Steel galvanized	100 pcs.	105020
	RO-flex 55/85/195 Screw nut M8x20 Steel nickel-plate	100 pcs.	105030

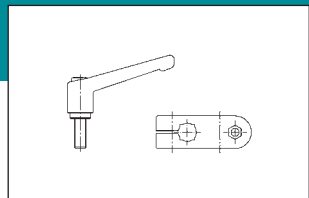

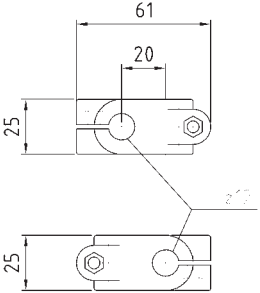
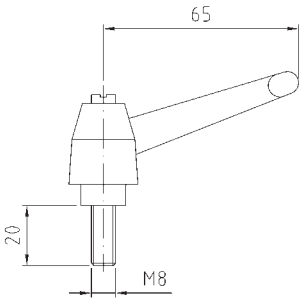
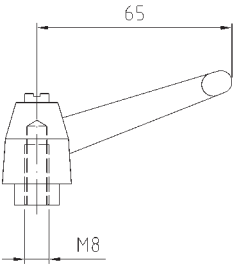
	Description	Unit	Art. No.
	<p>RO-flex 55/85/195</p> <p>Cross clamp AL</p> <p>Cast aluminium incl. fastening elements</p>	1 pcs.	107260
	<p>RO-flex 55/85/195</p> <p>Threaded chuck M8x20 outside</p> <p>PA 6 black/Steel galvanized</p>	1 pcs.	107502
	<p>RO-flex 55/85/195</p> <p>Threaded chuck M8 inside</p> <p>PA 6 black/Steel galvanized</p>	1 pcs.	107503

Accessories, general

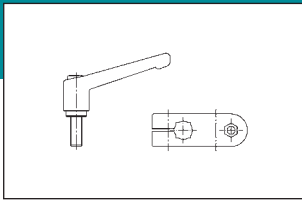

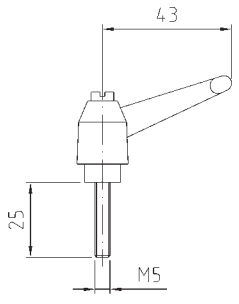
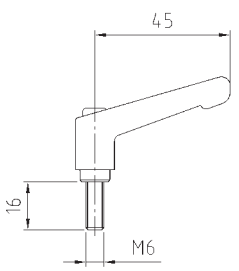
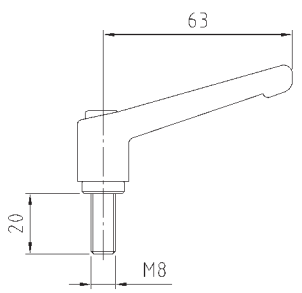
	Description	Unit	Art. No.
	<p>RO-flex 55/85/195</p> <p>Threaded chuck M5x25 outside</p> <p>PA 6 black/Steel galvanized</p>	1 pcs.	107504
	<p>RO-flex 55/85/195</p> <p>Threaded chuck M6x16 outside</p> <p>Stainless steel 1.4301, RAL 2004 orange</p>	1 pcs.	100155
	<p>RO-flex 55/85/195</p> <p>Threaded chuck M8x20 outside</p> <p>Stainless steel 1.4301, RAL 2004 orange</p>	1 pcs.	100156

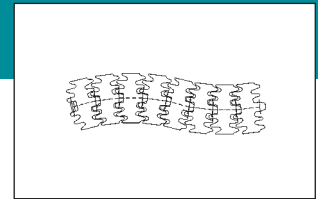

Chassis

The chassis of the RO-flex conveyors is composed of the aluminium profiles and the guide rails. These are delivered as bars with a length of 6 m each. The aluminium profile is also available in different blank cut lengths.

Two different guide rail materials are available. Guide rails from HDPE are used for dry run as they offer an extremely low friction value.

If a high chemical or thermal resistance is required, or if heavily accumulating operation is planned, it is recommended to use guide rails made from PVDF white.

The front part of each of the the guide rails must be fixed with plastic screws.

The systems RO-flex 55 and RO-flex-85 require 4 m of guide rail per running meter aluminium profile.

The system RO-flex 195 requires 8 m of guide rail per running meter aluminium profile.

A tool may be delivered for the assembly of the guide rail.

Chassis connections

The individual chassis profiles are linked on the outside using screwable connecting straps. Per strapped joint, 2 straps each are required for the systems RO-flex 55 and RO-flex 85, and 4 straps each for the system RO-flex 195.

Under high load, the strapped joints of the RO-flex 85 may be reinforced with 2 additional internal straps.

Specifications

Material:	chassis profile	aluminium anodized
	guide rails	HDPE gray PVDF white

Weights:	chassis profile 55	2.3 kg/m
	chassis profile 85	3.6 kg/m
	chassis profile 195	6.9 kg/m

Deflection:

RO-flex 55 max. permissible deflection 8.5 mm, at a lumped load of 30 kg, axis distance 3 m
 max. permissible deflection 8 mm, at an area load of 15 kg/m, axis distance 3 m

RO-flex 85 max. permissible deflection 10 mm, at a lumped load 60 kg, axis distance 3 m
 max. permissible deflection 10 mm, at an area load of 30 kg/m, axis distance 3 m

RO-flex 195 max. permissible deflection 10 mm, at a lumped load of 180 kg, axis distance 3 m
 max. permissible deflection 10 mm, at an area load of 90 kg/m, axis distance 3 m

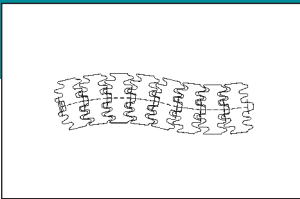

Chains

The horizontal and vertical curve-going chains RO-flex 55, RO-flex 85 and RO-flex 195 consist of wear and impact resistant POM plastic and stainless connecting bolts.

The systems RO-flex 55 and RO-flex 85 are equipped with geared chain links. The tothing offers 2 essential advantages:

- On straight lines, in curves as well as during drive and idler, the gap between the chain links does not bear the risk of accidents.
- Even the smallest parts (up to \varnothing 16 mm) may be conveyed or pushed on/off without any problem even in accumulating operation.

The chains RO-flex 195 are designed in a way that no risk of accidents occurs even in the curves through the chain plates opening.

To be able to convey the most different products also on ascending and descending slopes or even vertically, a multitude of belt cleats types are available. For detailed information, please, see the related chapter or call us for information.

Specifications

Material: chain POM white, other RAL colours available upon request.
bolt, stainless steel 1.4301

Temperatures operation between -40°C and $+90^{\circ}\text{C}$

Weights	RO-flex 55	0.44 kg/m
	RO-flex 85	1 kg/m
	RO-flex 195	2 kg/m

Tensile force	RO-flex 55	1,000 N
	RO-flex 85	2,200 N
	RO-flex 195	4,000 N

Packaging units	RO-flex 55	3 m
	RO-flex 85	3 m
	RO-flex 195	5 m

Radii min.	horizontal	RO-flex 55	125 mm
		RO-flex 85	200 mm
		RO-flex 195	600 mm
	vertical	RO-flex 55	300 mm
		RO-flex 85	400 mm
		RO-flex 195	600 mm

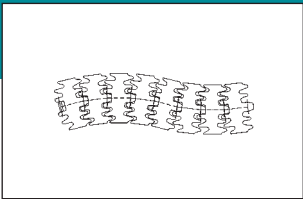

Drive stations

Head drive stations are to be used preferably. The head drive stations are installed at the end of the conveyor in conveying direction. The notation “right” and “left” refer to the configuration of the chain drive, viewed in conveying direction, with the motor at the bottom.

In addition to the head drives, center drives, arc bends and rotary drives may be delivered. Please see the various chapters for further information and specifications.

All drive stations may be delivered with or without motor. In both cases, the related motor plates for SEW S37 are included in the scope of delivery. Adapter plates for other motors available upon request.

For the design of the motor, we need speed, load and track routing of the conveyor. We provide example calculations upon request.

Specifications

Possible conveying speeds: $V = 6 - 60 \text{ m/min}$

Possible motor output: $P = 0.18 \text{ KW}$
 0.25 KW
 0.37 KW
 0.55 KW

Material: steel, galvanized / PE

Chain wheels: head drives are driven using chain wheels and roller chain. For the required chain wheels, please, see chapter Drive.

Design of the motor speed for head drive stations

Speed of the drive motor

Notation used:

$V =$ conveying speed (m/sec)
 $Z_M =$ number of teeth of the chain wheel – gear motor
 $Z_A =$ number of teeth of chain wheel – drive station
 $N_{ab} =$ output speed of the gear motor (rpm)

Calculation RO-flex 55

$$N_{ab} = 215 \times V \times Z_A / Z_M \quad (\text{rpm})$$

Calculation RO-flex 85 and RO-flex 195

$$N_{ab} = 155 \times V \times Z_A / Z_M \quad (\text{rpm})$$

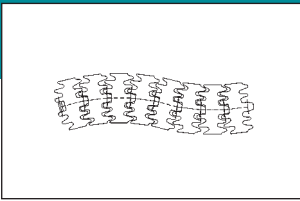

Idler units

In case of head drive stations, the idler units are installed at the end of the conveyor opposite to the conveying direction.

In case of center drives, 2 idler units are required.

For information about special idler units at 90° for chain guidance, e.g. on serpentines, please, see chapter Idler.

At the idler unit, an additional opening for the assembly/disassembly of the chain is provided.

Specifications:

Material: steel, galvanized / PE

Horizontal wheel bends

Horizontal direction changes with small radii should be made using wheel bends wherever possible. Through the ball bearing supported idler plates, the friction forces and thus wear and chain tensile force are extremely low. The installation space required must be taken into consideration when planning the system.

The connecting straps for the connection to a chassis profile are included in the scope of delivery.

The required guide rails must be ordered separately.

Specifications

Material: steel, galvanized / PA 6 / aluminium anodized

Radius: horizontal RO-flex 55 125 mm
RO-flex 85 200 mm

Planning notes:

RO-flex-55

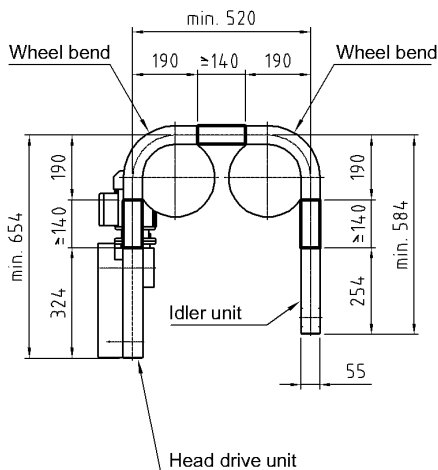

RO-flex-85

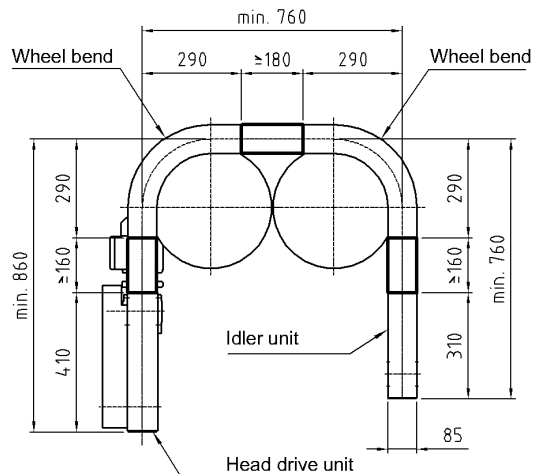

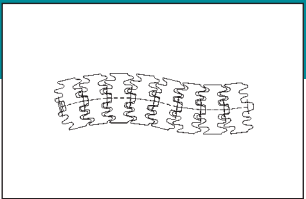

Bends

Horizontal bends

The horizontal bends are composed of solid PE material with an extremely low friction value against the chain material.

Despite of this, horizontal bends should only be used for the systems RO-flex 55 and RO-flex 85 if the use of wheel bends is impossible.

The connecting strips for the connection to the chassis profile are included in the scope of delivery.

For the connection of horizontal continuous bends to other components, please, observe the following planning notes.

Specifications

Material: steel, galvanized / PE

Radius:

horizontal	RO-flex 55	125 mm
	RO-flex 85	200 mm and 500 mm
	RO-flex 195	600 mm

Other radii available upon request

Angle:

horizontal	RO-flex 55	30°, 45°, 60°, 90°
	RO-flex 85	15°, 30°, 45°, 60°, 90°, 180°
	RO-flex-195	30°, 45°, 60°, 90°, 180°

Planning notes:

RO-flex-55

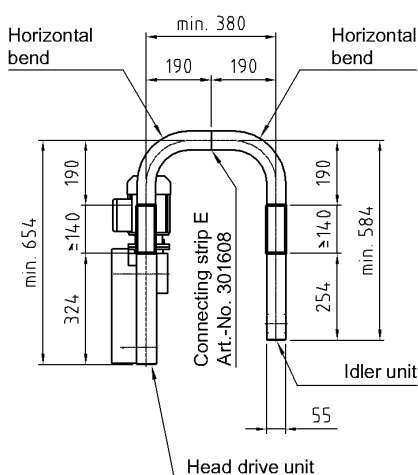

RO-flex-85

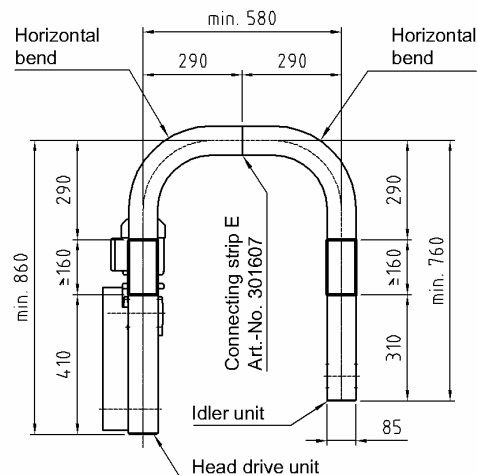

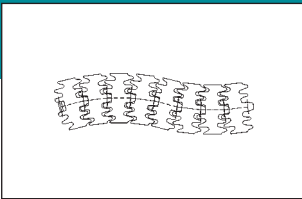

Vertical bends

The vertical bends are composed of bent aluminium profile. For realizing ascending/descending slopes, different angles are available. All components as well as the chassis may directly be connected to the vertical bends. The required connecting strips are included in the scope of delivery.

Specifications

Material: aluminium anodized / steel galvanized

Radius:

vertical	RO-flex 55	300 mm
	RO-flex 85	400 mm
	RO-flex 195	600 mm

Other radii available upon request

Angle:

vertical	RO-flex 55	5°, 10°, 15°, 30°, 45°, 60°, 90°
	RO-flex 85	5°, 10°, 15°, 30°, 45°, 60°, 90°
	RO-flex 195	5°, 10°, 15°, 30°, 45°, 60°, 90°

Planning notes:

RO-flex-55

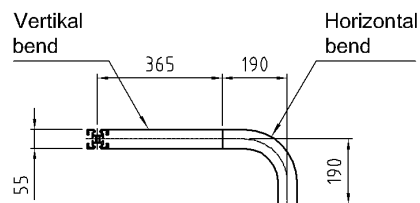

RO-flex-85

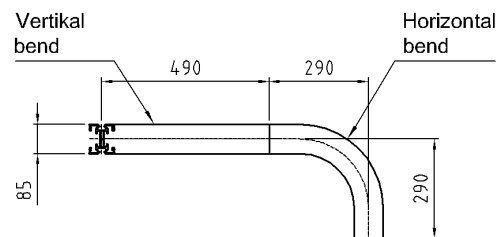

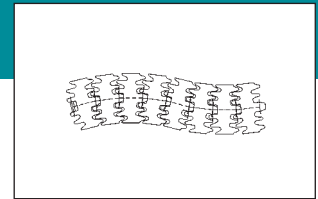

Supports

To support the conveyors, 2-leg and 3-leg supports are available. The support length may be defined using the pipe length, fine adjustment can be made using the threaded bars at the adjusting feet. The adjusting feet may be dowelled down.

In case of higher loads on the conveyor or for a higher support, an aluminium profile 100 x 100 with various fastening angles and base plates is available. The profile ends and grooves may be sealed using end caps and covering strips.

Specifications

Material:	2-leg/3-leg support pipe fastening elements profile 100 x 100 and 50 x 50	PA6 / steel, galvanized steel, galvanized PA6 / steel, galvanized aluminium anodised
Support heights:	2-leg/3-leg supports profile 100 x 100	H = 400 – 2,000 mm H = up to max. 4,000 mm

Side guides

The design of the side guides varies and depends on the product to be conveyed and the conveying situation. As standard, 3 side guide profiles are available for this purpose.

Using the elements offered, fixed, adjustable and variable side guides for most of the product shapes and sizes may be realized.

Specifications

Models:	side guide profile 20 x 20, aluminium anodised side guide profile 25 x 11, aluminium anodised, can be combined with RAPS protective strip side guide profile Ø 12 mm, steel, galvanized side guide profile Ø 12/8 mm, steel, galvanized / PA
----------------	--

Order information:	The intervals – and thus the number of side guide holders – depend on the conveying situation. In case of accumulating operation, a distance of 0.3 – 0.5 m may be necessary, in case of normal transport operation, intervals of 1 – 1.5 m may be sufficient.
---------------------------	---

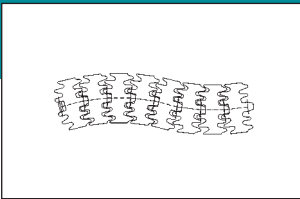

The following descriptions and calculations are meant as support to give you a survey of the following subjects:

- Systems and fields of application
- Calculations of chain tensile force and motor output
- Materials in the RO-flex conveying systems with mechanical, physical and chemical characteristics

SYSTEMS AND FIELDS OF APPLICATION

1. RO-flex 55, RO-flex 85 and RO-flex 195

Depending on the size and weight of the products to be conveyed, three different conveying widths - 55mm, 85mm or 195mm – may be used. Here, the material to be conveyed may have four times the width of the conveyer width. Depending on the position of the center of gravity, the products to be conveyed must additionally be supported at the side. The weight of the conveyed products is taken into account when calculating tensile force and motor output.

2. RO-flex ALUMINIUM

The RO-flex ALUMINIUM model is mainly used in **normal, dry environment** for packed products and with PVDF guide rail also in oily surroundings.

To all system widths, the following material specifications apply:

- profiles (chassis, supports, side guides, etc): aluminium anodized
- steel parts and components: St 37, St 50, electrogalvanized

3. RO-flex EDELSTAHL (separate catalog)

For **wet areas** and environments with increased hygienic requirements, as e.g. chemical, pharmaceutical and food industry, a complete program in stainless steel design offering the same system widths is available.

CALCULATION OF CHAIN TENSILE FORCE AND MOTOR OUTPUT

When determining the conveying lengths and routings of RO-flex conveyers, it is important that the generated **TENSILE FORCE** and **MOTOR OUTPUT** are calculated. Through the correct dimensioning of the conveyer, the motor output may be optimized thus avoiding increased wear.

Notation used

F_K = chain tensile force	[N]	k_α = bend factor	
L = conveying length	[m]	F_{zul} = max.perm. tensile force	[N]
w = chain weight *	[N/m]	P_M = drive motor output	[kW]
w_p = product weight w/o accumulation*	[N/m]	v = conveying speed	[ec]
q_{FS} = product weight w/ accumulation *	[N/m]	S = safety factor	
μ_1 = friction coefficient-guide rail		Z_A = teeth number - chain wheel - drive station	
μ_2 = friction coefficient-conveyed product		Z_M = teeth number – chain wheel – gear motor	
α = angle of horizontal bend		n_{ab} = output speed of gear motor	[rpm]
β = angle of vertical bend			

* uniform loads

Specifications

Table 1

Chain type	Material	Chain weight [N/m]	Max.perm. tensile force [N]
RO-flex 55	POM	4	1,000
RO-flex 85	POM	10	2,250
RO-flex 195	POM	25	4,000

Table 2

Bend type	Bend factor k_α
Vertical and horizontal continuous bends	
5° - 30°	1.2
45°	1.3
60°	1.4
90°	1.6
180°	2.6
Horizontal wheel bends (with ball bearing)	
30° - 60°	1.02
60° - 90°	1.05
180°	1.1
Drive stations, idler units (with ball bearing)	
Drive station	1.05
Deflection	1.05

Subject to technical changes!

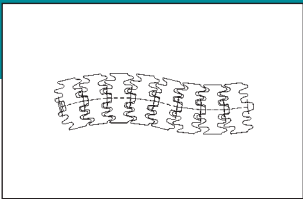

Table 3

Chain material	Lubrication	Friction coefficient μ_1			Friction coefficient μ_2			
		Chain guide rail		Chain - chassis stainless	Chaine – product to be conveyed			
		Material of guide rail			Material of conveying belt			
		PVDF	HDPE	Steel	Glass	Card-board	Plastic	
POM	dry	0.2	0.15	0.2	0.2	0.15	0.25	0.2
	water	0.15	0.15	0.2	0.15	0.15	-	0.15
	Silicon spray	0.1	0.1	0.15	-	-	-	-
	oil	0.1	-	0.1	0.1	-	-	-

These values are meant as reference values only and must be recalculated and determined specifically in extreme cases and in cases of doubt.

Chain tensile force

The chain tensile force generated results from the frictional forces which occur under the varying conveying situations and conditions. In order to avoid overload on the chain, the following must be true

$$F_{zul} \geq F_K$$

The following different conveying situations and conditions must be taken into account:

1. Conveyance without accumulation

Frictional force between RO-flex chain and guide rail or chassis with products to be conveyed loaded.

$$F_K = L \cdot (2 \cdot q_K + q_F) \cdot \mu_1$$

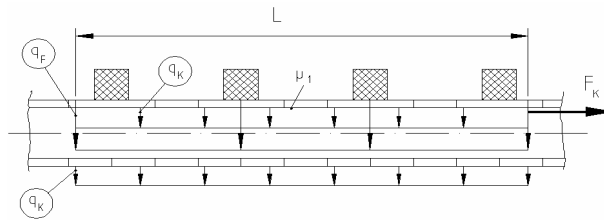

2. Conveyance with accumulation

In addition to 1., another frictional force acts between the RO-flex chain and the accumulated conveyed products.

$$F_K = L \cdot [(2 \cdot q_K + q_F) \cdot \mu_1 + q_{Fs} \cdot \mu_2]$$

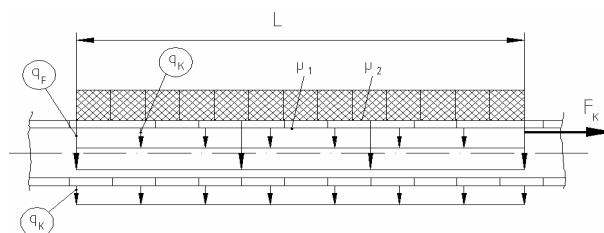

3. Conveyance with pusher dogs

In case of ascending conveyers with angle of inclination $\beta > 5^\circ$, the products to be conveyed must be taken long either by pusher dogs or on friction chain. In this way, the gravitational force matching the inclination angle is put on the products to be conveyed or their frictional force is reduced proportionally.

$$F_K = L \cdot (2 \cdot q_K + q_F) \cdot (\mu_1 \cdot \cos\alpha \cdot \sin\beta)$$

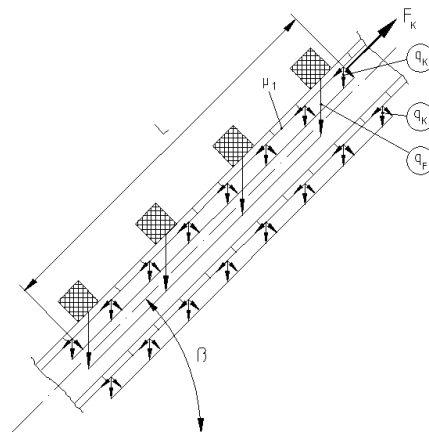

Subject to technical changes!

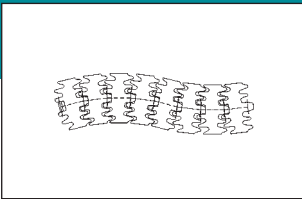

4. Bend factor

As the frictional force changes each time the direction is changed thus increasing the chain tensile force, the conveyer must be split up in segments. After each segment, the calculated chain tensile force is multiplied by k_{α} (s. table 2).

Calculation – chain tensile force

A conveyer with 'n' bends (direction changes) is divided up into 'n+1' segments. One segment always ends after one bend. The tensile forces at the related ends of the bends are added up where the first segment is the one the furthest away from the drive. The tensile force increase through drive and deflection is taken into account by multiplying the calculated tensile force by the accumulated bend factor 1,1.

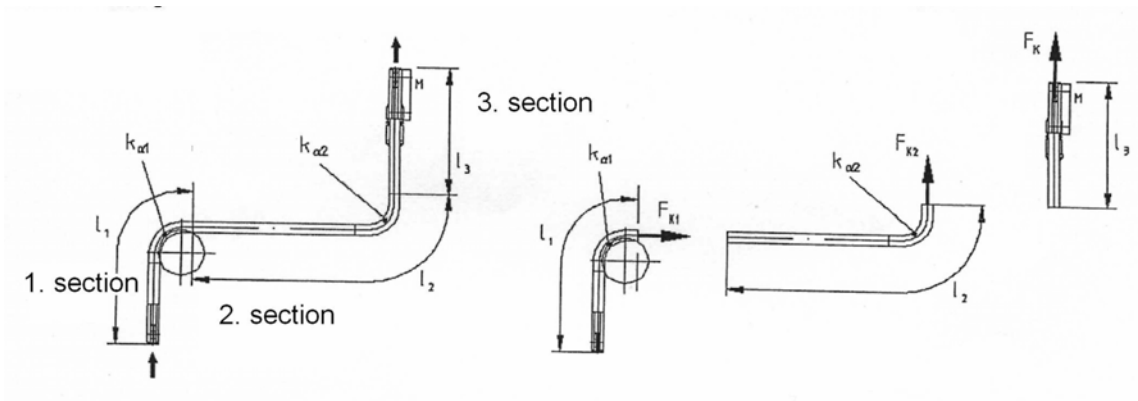

$$F_K = 1,1 \cdot \{ [(F_{K1} \cdot k_{\alpha 1} + F_{K2}) \cdot k_{\alpha 2} + F_{K3}] \cdot k_{\alpha 3} + F_{K4} \} \cdot k_{\alpha 4} \dots$$

Calculation – motor output

Motor output

The motor output P_M is calculated in accordance with the following formula:

$$P_M = \frac{S \cdot F_K \cdot v}{1,000} \text{ [kW]}$$

The **safety factor S** takes into account unknown operation conditions (contamination, temperature, or similar) and can be set to $S = 1.5 \dots 2.5$.

Speed (RO-flex 55)

The output speed n_{ab} of the gear motor is calculated in accordance with the following formula:

$$n_{ab} = 215 \cdot v \cdot \frac{Z_A}{Z_M} \text{ [rpm]}$$

Speed (RO-flex 85 and 195)

The output speed n_{ab} of the gear motor is calculated in accordance with the following formula:

$$n_{ab} = 155 \cdot v \cdot \frac{Z_A}{Z_M} \text{ [rpm]}$$

Subject to technical changes!

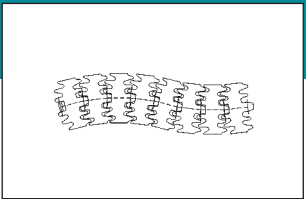

Example calculation RO-flex 85 conveyor with accumulating track

$n = 2$ bends $\Rightarrow 3$ segments !

Given data :

Product to be conveyed: cardboard boxes $m = 2$ kg
 $l \cdot w \cdot h = 250 \cdot 200 \cdot 100$
 25 pcs/min
 $v = 0.4$ m/sec
 $l_{ges} = 19.5$ m
 $l_1 = 6.5$ m
 $l_2 = 9.2$ m
 $l_3 = 3.8$ m (accumulation track)
 Chain: RO-flex 85 POM $\Rightarrow q_K = 10$ N/m
 Guide rail: HDPE (dry run)
 $\Rightarrow \mu_1 = 0.15$
 w/o accumulation: $\Rightarrow q_F \approx 20$ N/m
 w/ accumulation: $\Rightarrow q_{FS} \approx 80$ N/m
 $\Rightarrow \mu_2 = 0.25$

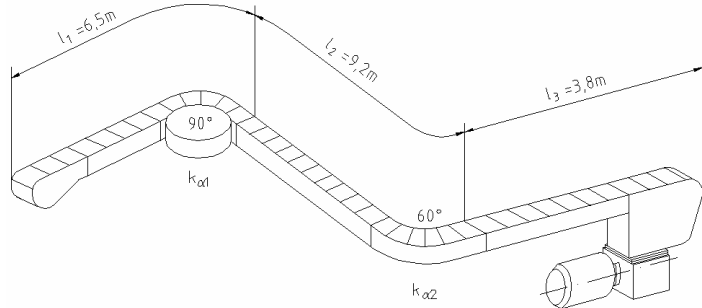

Chain tensile force

$$F_K = 1,1 \cdot [(F_{K1} \cdot k_{\alpha 1} + F_{K2}) \cdot k_{\alpha 2} + F_{K3}] \cdot k_{\alpha 3}$$

1st section w/o accumulation

$$F_{K1} = l_1 \cdot (2q_K + q_F) \cdot \mu_1$$

$$\mu_1 = 0.15, \text{ from table 3}$$

$$F_{K1} = 6.5 \cdot (2 \cdot 10 + 20) \cdot 0.15 = 39 \text{ N}$$

2nd section w/o accumulation

$$F_{K2} = l_2 \cdot (2q_K + q_F) \cdot \mu_1$$

$$F_{K2} = 9.2 \cdot (2 \cdot 10 + 20) \cdot 0.15 = 55.2 \text{ N}$$

3rd section w/ accumulation

$$F_{K3} = l_3 \cdot [(2q_K + q_{FS}) \cdot \mu_1 + q_{FS} \cdot \mu_2]$$

$$\mu_2 = 0.25, \text{ from table 3}$$

$$F_{K3} = 3.8 \cdot (2 \cdot 10 + 90) \cdot 0.15 + 90 \cdot 0.25 = 148 \text{ N}$$

with $k_{\alpha 1} = 1.05$ and $k_{\alpha 2} = 1.6$, from table 2
 $\Rightarrow F_K = 1,1 \cdot [(39 \cdot 1.05 + 55.2) \cdot 1.6 + 148] = 332 \text{ N}$

with $F_{zul} = 2250 \text{ N} \Rightarrow F_K < F_{zul}$

Motor output

$$P_M = \frac{S \cdot F_K \cdot v}{1,000} \text{ [kW]} = \frac{2.5 \cdot 332 \cdot 0.4}{1,000} = 0.332 \text{ kW}$$

$P_M = 0.332 \text{ kW} \Rightarrow$ selected $P_M = 0.37 \text{ kW}$

Speed

$$n_{ab} = 155 \cdot v \cdot \frac{Z_A}{Z_M} \text{ [rpm]} = 155 \cdot 0.4 \cdot \frac{19}{19} = 62 \text{ rpm}$$

Subject to technical changes!

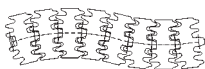

Materials in the RO-flex Conveying Systems

The following table includes the most important mechanical and physical characteristics

Material:	Density kg/m ³	E module N/mm ²	Tensile strength N/mm ²	Water absorption %
Aluminium anodized AlMgSi 0,5 / F25	2,700	65,000	280	-
Steel electrogalvanized St 37	7,850	210,000	390	-
Steel stainless Wst.No. 1.4301	7,900	200,000	500	-
Polyamide fiber glass reenforced PA 6.6 - 30GF	1,360	8,000	180	6.6
Polycarbonate fiber glass reenforced PC - 30GF	1,430	5,500	75	0.3
Polyethylene high-molecular HDPE	950	1,000	25	0.02
Polypropylene calcium reenforced PP - 40CA	1,160	1,500	40	0.03
Acetal , POM	1,410	3,000	70	0.8
Polyvinyl chloride , PVC	1,440	3,100	54	0.04
Polyvinylidene fluoride , PVDF	1,780	1,800	50	0.1
Polystyrene , PS	1,050	3,300	50	0.5

Temperature limit values in operation

- 40°C to + 90°C

The operational temperature limit values are determined by the plastics used for chains and guide rail. They may change under defined operation conditions. When operating the conveyer close to the temperature limits, the values in the table above may also change under certain circumstances, as do motor and wear. In particular cases, please, contact us for further consulting.

Resistance to Chemicals

Explanation		Data refer to normal conditions ! Under the influence of temperature, characteristics may change considerably.							
a = no identifiable attack (resistant)									
b = limited resistance, depending on requirement in the individual case – praxis test recommended									
c = heavy material attack, use not recommendable									
Chemical:	Active ingredient								
	PA 6.6-30GF	PC-30GF	HDPE	PP-40Ca	POM	PVC	PVDF	PS	Aluminium anodized
Acetone	a	c	a	a	a	-	b	c	a
Formic Acid	a	b	a	a	c	a	a	a	b
Ammonia , 50%	-	c	a	a	a	a	a	a	b
Amyle alcohol	-	a	a	a	c	a	a	a	b
Aniline	b	c	a	a	b	-	a	c	a
Arsenous acid	-	a	a	a	-	-	a	-	b
Benzin	a	a	a	b	a	a	a	c	a
Benzoic acid	b	c	a	a	b	-	a	a	a
Benzene	a	c	b	b	a	c	a	c	b
Hydrocyanic acid	-	-	a	a	-	-	a	-	a
Boric acid	-	a	a	a	a	a	a	a	a
Butadiene	-	-	-	-	a	-	a	-	a
Butanoic acid	b	c	a	a	a	-	a	c	b
Butyl glycol	a	a	-	-	a	-	a	a	a
Calcium carbonate	-	-	a	a	-	a	a	-	a
Chlorine, wet	c	c	c	c	c	c	a	-	c
Chlorine, dry	c	c	b	c	b	b	a	-	a
Chlorobenzene	a	c	b	-	a	c	a	-	a
Chloroform	-	c	c	b	b	-	a	c	b
Chromate , 50%	-	a	b	b	c	-	a	a	b
Diesel fuel	a	b	a	a	a	a	a	a	a
Natural gas	-	-	-	-	a	a	a	-	a

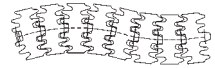

Chemical	Active ingredient								
	PA 6.6 30GF	PC 30GF	HDPE	PP 40Ca	POM	PVC	PVDF	RABS	Aluminium anodized
Petroleum	b	-	a	b	a	a	a	-	a
Acetic acid , 50%	b	a	a	a	b	a	a	a	a
Acetic acid , 100%	c	c	a	a	c	b	a	a	a
Ethyl alcohol	a	a	a	a	a	a	a	-	-
Fats, fatty acids	c	-	a	a	a	-	a	-	a
Hydrofluoric acid	a	c	-	-	-	a	a	a	-
Formaldehyde	-	a	a	a	a	a	a	a	b
Cereal oil	-	-	b	b	-	-	a	-	b
Transmission oil	a	a	a	b	b	a	a	-	a
Glucose	-	-	a	a	-	-	a	-	a
Heating oil	a	b	a	a	a	a	a	-	a
Iodine, wet	-	c	a	a	-	b	a	b	b
Potassium carbonate	-	b	a	a	-	a	a	-	c
Potassium permanganate	b	a	a	a	a	a	a	b	a
Potassium sulfate	-	a	a	a	-	a	a	a	a
Aqua regia	c	c	c	c	c	-	a	b	c
Carbondioxide, wet	-	a	a	a	a	a	a	-	a
Carbon dioxide, dry	-	a	a	a	a	a	a	-	a
Coco oil	-	-	a	a	b	a	a	-	a
Linseed oil	-	a	a	a	a	a	a	-	a
Methanol	b	c	a	a	a	a	a	b	a
Methylethyl keton	a	c	a	a	b	c	b	c	-
Milk	b	a	a	a	a	a	a	a	a
Lactic acid	b	a	a	a	a	a	a	a	b
Mineral oil	a	a	a	a	a	a	a	-	a
Sodium carbonate	a	a	a	a	b	a	a	a	b
Sodium cyanide	-	-	a	a	-	-	a	-	a
Sodium hydroxide , 50%	a	c	a	a	a	a	a	a	b
Nicotinic acid	-	-	a	b	-	-	a	-	a
Nitrobenzene	b	c	a	a	b	a/b	a	-	a
Oxalic acid	--	a	a	a	-	a	a	a	a
Perchloric acid , 10%	-	a	a	a	b	-	a	-	c
Phosphoric acid , 85%	b	a	a	a	b	a	a	a	b
Propane	a	a	a	a	a	a	a	-	a
Mercury	a	a	a	a	a	a	a	a	a
Crude oil	-	-	a	b	a	a	a	-	a
Nitric acid , 65 %	c	c	b	b	c	a	a	b	b
Hydrochloric acid , conc.	c	c	b	b	c	a	a	a	b
Sulfur dioxide	a	b	a	a	c	a	a	-	a
Sulfuric acid , 50%	c	a	a	a	c	a	a	a	b
Sulfuric acid , 95%	c	c	b	b	c	a	a	b	a
Hydrogen sulfide	a	a	a	a	a	a	a	b	a
Carbon tetrachloride	a	c	c	c	b	c	a	c	a
Water	a	a	a	a	a	a	a	a	a
Hydrogen peroxide ,30%	a	a	a	a	b	a	a	b	a
Citric acid , 50%	a	(10%) a	a	a	b	a	a	b	a

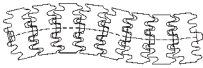

Safety instructions

General

The operator or personnel authorized by him and in charge of operating the system in accordance with their assigned tasks are solely responsible for the accident-free operation.

Occupational safety

The observance of the information on occupational safety helps to prevent any danger to persons, the environment and / or the system.

The non-observance of these information may cause the following risks under given circumstances:

- Danger to persons through mechanical, electrical, pneumatic influences
- Danger to the environment through cleaning agents and disinfectants, oils and grease
- Failure or destruction of the entire system or of individual machine parts

Before switching on the main switch, the system must be subject to an inspection.

During the start-up phase following a system restart, the system must continuously be monitored by the competent staff.

The system may only be released for regular operation after the personnel in charge have convinced themselves of the proper and safe operation and function of the entire system.

Safety and monitoring devices

In order to ensure the safety of the users in normal operation, the system is equipped with appropriate safety devices and facilities (contact protection, etc.).

Removal of safety devices

The system may never be operated without the protective and safety devices installed at the system. Before removing any safety devices (stationary and movable accident-prevention covers), the system must be shut down completely with the main switch and be protected from being switched on again unintentionally.

Maintenance

Maintenance works may only be carried out with the system stopped, i.e. with the main switch switched off (set to the O position) and secured against being switched on again using a padlock.

For all works related to operation, assembly and maintenance, the shutdown procedure and – where applicable – the required safety measures must be observed without fail.

During all production interruptions and downtimes, it must be ensured that all required safety devices are installed. Following all assembly and maintenance works it must be checked whether all safety devices are mounted and function perfectly.

Safety devices may never be bridged, bypassed or made inoperable.

Following all assembly and maintenance works, the system must be checked for left objects (tools, etc.). Such objects must be removed in order to avoid machine damage.

For the execution of certain maintenance works only professional personnel in the sense of subsection „Requirements on the personnel“ in this chapter may be employed. This particularly applies to works at pneumatic or electrical facilities.

During due function tests, the main switch may only remain switched on for the time required for the test.

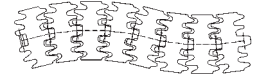

The operating staff working with and at the system must be informed about the maintenance works and may not operate the system for the period of such works.

For the maintenance and lubrication of the various assemblies and components, the related maintenance instructions and lubricant charts must be observed.

Before restarting the system, the completeness and correct execution of all maintenance works in accordance with the said regulations and information must be checked.

Emergency information

Rescue of people / First aid

In case of dangers or accidents, the system must be stopped immediately by actuating the EMERGENCY OFF pushbutton.

This can also be executed by opening a protective door or a protective window which is equipped with a safety switch and which triggers the EMERGENCY OFF function when opening it.

The EMERGENCY OFF function triggers an immediate system stop, with no consideration of the present position of the machine elements.

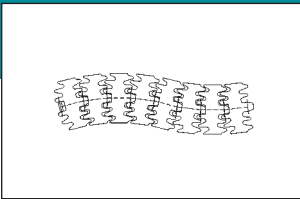

Maintenance

Remarks b) After a malfunction has been detected (also outside the service intervals), the defect must be removed without delay. See chapter "Repair".	Maintenance intervals in 1-shift operation					Operator	Service engineer	
	1 weekly	2 every three months	3 every six months	4 annually				
	0	1	2	3	4			
Check point								
General: Before commissioning the system, make sure it is completely clean and in faultless condition. All assemblies and components must be free from foreign objects (as e.g. screws, screwdrivers, etc.).								
Frame and link chain:								
Check the screw connections around the cross beams at the high-grade steel frame	b)			•		•	•	
Damaged chain links with or without tappets must be replaced without delay in order to prevent damage to frame and plastic sprocket wheels/drums	b)		•			•		
<u>Check longitudinal elongation:</u> If the link chain becomes visible in the lower frame area of the drive station, the chain must be shortened by approx. 1 to 2 links or more.	b)	•				•	•	
In case of systems with horizontal and/or vertical bends, the link chain must be lubricated with silicone grease.	b)		•			•		
Link chains with friction rubber inserts or accumulating roller (if being used) must be checked for damage in regular intervals. Damage might affect the take-along function of the chain.	b)	•				•		
Drive and idler station:								
Before starting any inspection and maintenance works at the drive station, the gear motor must be disconnected from the power supply and be protected against unintentional reactivation.								
The ball-bearing support points of idler station, drive station and wheel bend are permanently lubricated.	b)				•		•	
Check tension of the roller chain at the drive station.	b)		•				•	
Check roller chain and sprocket wheels of gear motor and shaft of jointed band conveyor for wear.	b)			•		•		
Check bearings and gears / motor plate for their firm seat.	b)		•					
Maintenance and service of the gear motor; proceed in accordance with the manufacturer's specifications					•		•	

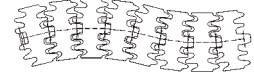

Check the gear housing, bleeding screws, and shaft seals for leakage	b)		•				•	
Check brake with motor decelerated and readjust, if necessary.	b)		•				•	
Check the power consumption of the motor.	b)		•				•	
Diverse:								
Check horizontal and vertical slide bends for wear (any abnormal operation noise, irregular/rough running of the chain) lubricate with silicone spray if necessary.	b)		•			•		
Check sliding gibs of the standard model for wear and replace if necessary.	b)		•			•		
Check round belts, transition rollers and bearings of the transitions (if installed) for wear and replace if necessary.	b)		•					
Check screwed connections: (if installed) - gear motor - head plate, tensioning plates, drive plates - frame, supports - switching elements - transitions - protective devices - side guides	b)				•		•	
Check cotter splint connections: (if installed) - shafts, axes - switching elements - lock washers	b)				•		•	

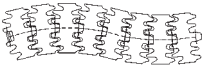

Repair

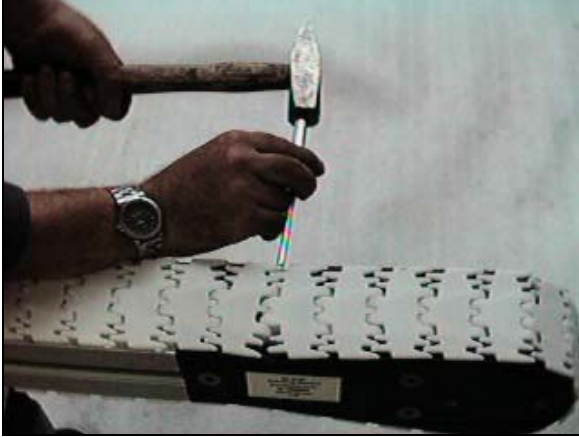

Disassembly of a chain link



Disassembly of the link chain

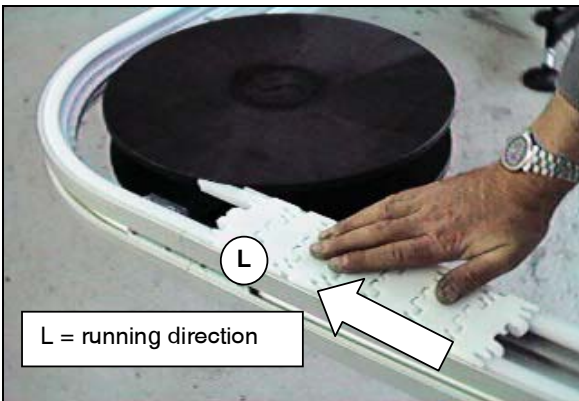

Check the running direction of the link chain

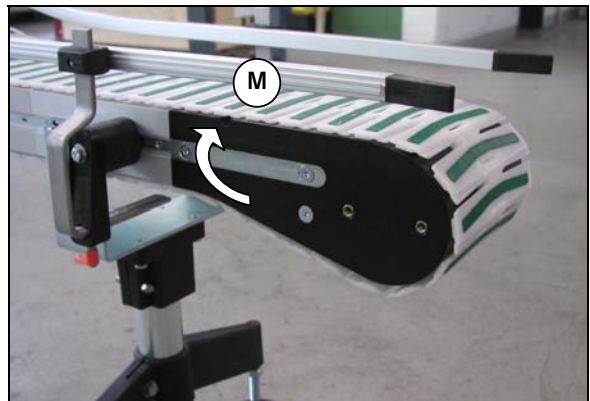

Lubrication of the link chain with silicone spray

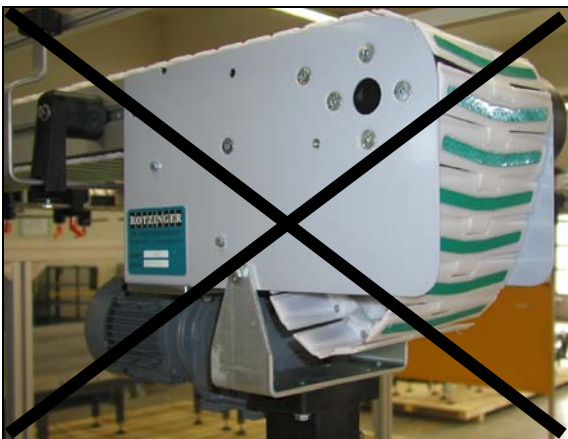

WRONG: tension of the assembled chain too low



CORRECT: chain tension correct

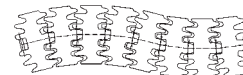

Check the butt joints and transitions



Check the new sliding gibs



Cut the end of the sliding gib at right angles



Clip it the sliding gib



Sliding gib must be trimmed to fit the shape of the bend wheel



Sliding gib must be cut to be flush with the drive station

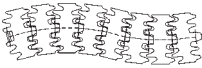

Mount the sliding grib in an offset way

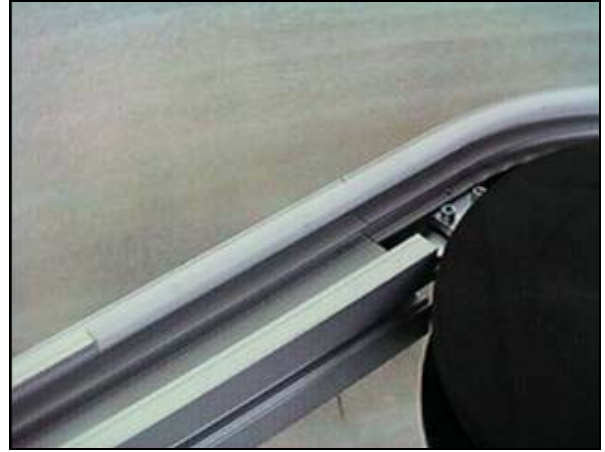

Pull the sliding gibs over the joints of the aluminium profile



Each sliding grib must be fixed at the beginning (as viewed in running direction)



Apply primer and plastic glue

